

Vulnerability assessment of surface water supply systems due to climate change and other impacts in Addis Ababa, Ethiopia

Risikanalys av ytvattenförsörjning med avseende på klimatförändring och andra effekter i Addis Abeba, Etiopien

Daniel Elala

Abstract

Vulnerability assessment of surface water supply systems due to climate change and other impacts in Addis Ababa, Ethiopia

Daniel Elala

In Addis Ababa, Ethiopia, open reservoirs provide the majority of the drinking water. In the study present and future condition of these water sources and supplies were systematically assessed regarding water quantities. The study was done by reviewing municipal documents and accessing meteorological, hydrological and demographical data in Addis Ababa. 0%, 5% and 10% change in reservoir inflow/rainfall were used and projections for 2020 and 2030 were used to estimate future temperature and population sizes. The result indicated that supplied water quantity per capita from surface sources in Addis Ababa is likely to be reduced. Both climate and socio-economic related vulnerabilities were identified and the four following got the highest risk score: Increases in population, increased per capita water demand, overexploited land and increased distribution losses.

At present the annual increase in population in Ethiopia is 4.4% and annual GDP increase is 7%, leading to a growing water demand in Addis Ababa. If the water supplies are not substantially increased the situation will lead to water scarcity. By 2020 water demand coverage will be 34% and by 2030 22%, compared with the current 50% coverage.

Overexploited land was also identified as a major vulnerability due to the impact on catchment hydrology and distribution losses, caused by insufficient maintenance and replacement of aged pipes. At present 20% of the treated water is lost and it is likely to increase during the coming decades. However, the climate change induced rainfall variability is unlikely to cause large problems within the observed timeframe. Even with a 100 year drought 14% of the available water would be spill due to the limited reservoir capacity.

To secure future water distribution Addis Ababa Water and Sewerage Authority (AAWSA) should build dams north of the Entoto ridge. They should also gain further understanding about and find appropriate measures for, highlighted vulnerabilities. A full vulnerability assessment should be done by AAWSA and they should consider implementing a 'Water Safety Plan' for the whole water supply system.

Keywords: Addis Ababa, surface water reservoirs, vulnerability assessment, climate change

Department of Earth Sciences, Aquatic Climatology, Uppsala University, Villavägen 16, SE 752 36 Uppsala, Sweden.

Referat

Risakanalys av ytvattenförsörjning med avseende på klimatförändring och andra effekter i Addis Abeba, Etiopien

Daniel Elala

I Addis Abeba, Etiopien, tillhandahålls majoriteten av dricksvatten från ytvattenreservoarer. Den nuvarande och framtida situationen för dessa reservoarer och deras vattendistribution har i denna studie systematiskt granskats med avseende på vattenkvantitet. I studien ingick en genomgång av myndighetsdokument samt meteorologiska, hydrologiska och demografiska data vilket var tillgängligt i Addis Abeba. 0%, 5% och 10% förändring i reservoarinflöde/nederbörd användes och prognoser för åren 2020 och 2030 har använts för att beräkna framtida temperaturer och befolkningsstorlekar. Resultatet visade att vattenmängden per capita från reservoarerna till Addis Abeba sannolikt kommer att minska. Både klimat- och socioekonomiskt relaterade risker identifierades och följande fyra fick högst riskpoäng: Ökad befolkning, ökad efterfrågan på vatten per capita, överutnyttjade markresurser samt ökade förluster vid distribution.

Den årliga befolkningstillväxten i Etiopien är för närvarande 4,4% och BNP-tillväxten är 7% per år, vilket leder till en växande efterfrågan på vatten i Addis Abeba. Om inte tillgången på vatten ökar väsentligt kommer det att leda till vattenbrist. År 2020 kommer 34% av vattenbehovet att kunna tillgodoses och 2030 endast 22%, jämfört med i dag då 50% av vattenbehovet tillgodoses.

Överutnyttjad mark identifierades också som en vattenkvantitetsrisk på grund av dess påverkan på avrinningsområdets hydrologi. Även distributionsförluster identifierades som en av de större riskerna, orsakade av bristande underhåll av gamla distributionsledningar. För närvarande förloras 20% av det renade vattnet och den procentsatsen kommer sannolikt att öka under kommande decennier. Klimatförändringens effekt på regnvariabilitet kommer troligen inte orsaka några större problem. Även med en torka med återkomsttiden 100 år skulle fortfarande 14% av det tillgängliga vattnet inte kunna samlas upp på grund av reservoarnas begränsade kapacitet.

För att säkra framtida vattendistribution bör AAWSA bygga dammar norr om Entoto bergen. Det behövs även ytterligare kunskap kring, och lämpliga åtgärder för, de ovannämnda fyra riskerna. En fullständig riskanalys av Addis Abebas vattentillgångar och vattendistributionen bör göras av AAWSA och de bör överväga att implementera en 'Water Safety Plan' för hela vattensystemet.

Nyckelord: Addis Abeba, ytvattenreservoarer, riskanalys, klimatförändring

Institutionen för geovetenskaper, akvatisk klimatologi, Uppsala universitet, Villavägen 16, 752 36 Uppsala

Acknowledgement

First I want to thank those who have been involved in the planning and completing of this thesis work (30 hp) in Aquatic and Environmental Science at Uppsala University. I want to thank subject reviewer Kevin Bishop, supervisor Solomon Gebreyohannis Gebrehiwot, on-site supervisors Woldeamlak Bewket and Mekonnen Adnew. Thank you for the encouragement, supervision and guidance. I also want to thank the staff at Addis Ababa Water and Sewerage Authority for making needed documents available and their professional way. Finally I want to thank SIDA and 'Arbetsgruppen för Tropisk Ekologi' for giving me the funding that enabled me to do my thesis in Ethiopia.

Daniel Elala

Uppsala, August 2011

Copyright© Daniel Elala and Department of Earth Sciences, Aquatic Climatology, Uppsala University.

UPTEC W 11 026, ISSN 1401-5765

Printed at the Department of Earth Sciences, Geotryckeriet, Uppsala University, Uppsala, 2011

Populärvetenskaplig sammanfattning

Risikanaly av ytvattenförsörjning med avseende på klimatförändring och andra effekter i Addis Abeba, Etiopien

Daniel Elala

I Addis Abeba, Etiopiens huvudstad, jobbar myndigheterna hårt med att tillgodose stadens invånare med rent vatten i tillräcklig mängd. Detta kräver relativt stora resurser, för ett land som är bland de fattigaste i världen. Etiopien är ett av de länder som har ålagt sig att arbeta för att halvera fattigdomen på jorden till år 2015 genom FN:s så kallade Millenniemålen. Tillgång till säkert vatten är ett av delmålen (Mål 7.8). Addis Abebas befolkningsantal ökar snabbt, framför allt på grund av inflyttning från landsbygden. Ökar gör också folkets levnadsstandard och krav på varor och tjänster, inklusive vattentjänster. En annan aspekt är effekterna på vattenförsörjningen i Addis Abeba på grund av klimatförändringarna. I denna studie har risknivån av dessa, och andra hot som kan bidra till vattenbrist, analyserats och mängden tillgängligt vatten uppskattats för den nuvarande situationen och för framtiden.

I Addis Abeba tillhandahålls dricksvatten huvudsakligen med hjälp av fördämningar som skapar ytvattenreservoarer så att ytvattnet kan användas under hela året och inte bara under regnperioden. Denna studie har baserats på väder-, vatten- och befolkningsdata och framtida temperaturer och befolkningsstorlekar har beräknats för att ge prognoser för åren 2020 och 2030. Även rapporter och andra dokument rörande vatten från reservoarerna har använts.

Resultatet visade att vattenmängden per person från Addis Abebas reservoarer sannolikt kommer att minska från att 50% av behoven tillgodoses i dagsläget, till år 2020 då uppskattningsvis 34% av behoven kommer att tillgodoses och år 2030 beräknades samma siffra till endast 22%. Om inte nya dammar byggs så att tillgången på vatten ökar väsentligt kommer det att leda till vattenbrist. Denna slutsats delas av både litteraturen och experter på myndigheter.

I riskanalysen identifierades följande fyra risker som de som hade högst riskpoäng: Ökad befolkning, ökad efterfrågan på vatten per person, överutnyttjade markresurser samt ökade förluster vid distribution av vattnet.

Den årliga befolkningstillväxten i Etiopien är för närvarande 4,4% och BNP-tillväxten är 7% per år, vilket leder till en växande efterfrågan på vatten i Addis Abeba. Varje år ansluter myndigheterna upp till 9000 nya hushåll till vattennätet, vilket ändå inte är tillräckligt för att tillgodose behovet.

Överutnyttjad mark identifierades också som en bidragande faktor till vattenbrist på grund av dess påverkan på hur vatten lagras i marken. Avskogningen kring Addis Abeba är sannolikt orsaken till att många av de små forsarna som tidigare hade ett vattenflöde året om idag slutar rinna under torrperioden. Även distributionsförluster identifierades som en av de större riskerna. Distributionsförlusterna orsakas av bristande underhåll och ej genomförda byten av gamla distributionsledningar. Många av ledningarna är mer än 40 år gamla. För närvarande förloras 20% av det renade vattnet och den procentsatsen kommer sannolikt att öka de kommande decennierna om det inte

satsas resurser på underhåll, eftersom då fler blir anslutna till distributionsnätet ökar trycket i systemet och mer vatten läcker.

Klimatförändringens effekt på regnets karaktär kommer troligen inte orsaka några större problem för vattenförsörjningen så som den nu är utformad. Även med en så pass allvarlig torka att sannolikheten att den inträffar är 1 på 100 år skulle fortfarande 14% av det tillgängliga vattnet inte kunna samlas upp och brukas på grund av reservoarernas begränsade kapacitet.

För att säkra framtida vattendistribution bör AAWSA bygga dammar norr om Entotobergen som är belägna norr om Addis Abeba, vilket det också finns långt gångna planer på. Men på grund av sociala, ekonomiska och politiska angelägenheter har dock detta inte gått att genomföra. Vidare behövs även ytterligare kunskap kring, och lämpliga åtgärder för, de ovannämnda fyra riskerna. En fullständig riskanalys bör göras av AAWSA och de bör överväga att implementera en heltäckande vattensäkerhets plan (Water Safty Plan) för hela vattensystemet. Denna typ av åtgärd rekommenderas även av WHO(World Health Organization).

TABLE OF CONTENTS

ABSTRACT.....	i
REFERAT.....	ii
ACKNOWLEDGEMENT.....	ii
POPULÄRVETENSKAPLIG SAMMANFATTNING.....	iv
TABLE OF CONTENTS.....	vi
APPENDICES.....	viii
ABBREVIATIONS.....	ix
1 INTRODUCTION.....	1
1.1 POPULATION GROWTH AND URBANISATION.....	1
1.2 DEVELOPMENT.....	1
1.3 HEALTH AND SOCIO-ECONOMIC SITUATION	2
1.4 OVER EXPLOITED LAND.....	2
1.5 JUSTIFICATION OF THE STUDY.....	2
1.6 HYPOTHESIS.....	3
1.7AIMS.....	3
1.8 SPECIFIC AIMS.....	3
2 BACKGROUND.....	4
2.1 CLIMATE CHANGE.....	4
2.1.1 Climate change in Ethiopia	4
2.1.2 Climate models.....	7
2.2 EXTREME WEATHER EVENTS.....	7
2.3 RESERVOIRS.....	9
2.3.1 Evaporation and seepages.....	9
2.3.2Life expectancy.....	10
2.3.3 Climate change and reservoirs	10
2.4 WATER DISTRIBUTION	10
2.4.1 Piped water supply.....	10

2.4.2 Increased average rainfall	10
2.4.3 Increased rainfall intensity.....	10
2.4.4 Decreased average rainfall.....	11
2.4.5 Energy dependency.....	11
2.4.6 Distribution vulnerability	11
2.5 WATER DEMAND.....	11
2.5.1 Water scarcity.....	11
2.5.2 Quantifying water demand.....	13
2.6 VULNERABILITY ASSESSMENT.....	14
2.6.1 The need of research.....	14
2.6.2 Water Safety Plan	14
3 ADDIS ABABA - AREA DESCRIPTION.....	15
3.1 CLIMATE.....	15
3.2 GEOGRAPHY.....	15
3.3 URBAN GROWTH.....	16
3.4 WATER SUPPLY.....	16
4 METHODOLOGY.....	19
4.1 AVAILIABLE DOUCUMENTS AND KEY INFORMANT MEETINGS.....	19
4.2 WATER BALANCE.....	19
4.2.1 Water balance model of the reservoirs.....	19
4.2.2 Runoff.....	20
4.2.3 Direct rainfall.....	20
4.2.4 Treatment plant intake.....	20
4.2.5 Seepage.....	21
4.2.6 Evaporation.....	21
4.3 WATER DEMAND	21
4.3.1 Average daily demand	21
4.3.2 Distribution losses.....	22
4.3.3 Population extrapolation.....	22

4.4 VULNERABILITY ASSESSMENT.....	22
5 RESULTS.....	24
5.1 PRESENT WATER BALANCE.....	24
5.2 FUTURE WATER BALANCE.....	25
5.3 WATER DEMAND.....	27
5.4 RAINFALL EXTREMES.....	29
5.5 VULNERABILITY ASSESSMENT.....	30
6 DISCUSSION.....	34
6.1 VULNERABILITIES FOR THE SURFACE SUPPLY.....	34
6.2 WATER DEMAND.....	34
6.3 WATER AVAILABILITY.....	34
6.4 OVEREXPLOITED LAND.....	35
6.5 DISTRIBUTION LOSSES.....	35
6.6 FUTURE DEVELOPMENT.....	36
6.7 LIMITATIONS.....	36
7 RECOMMENDATIONS.....	38
8 CONCLUSIONS.....	39
9 REFERENCES.....	40
APPENDICES	
Appendix A. The simplified Penman equation evaporation calculation.....	45
Appendix B. The monthly rainfall data that was used.....	46
Appendix C. 2020 and 2030 sub flows for all scenarios.....	46

ABBREVIATIONS

AAWSA	Addis Ababa Water and Sewerage Authority
ADD	Average Daily Demand
CIWD	Commercial and Institutional Water Demand
DIFID	Department for International development
DWD	Domestic Water Demand
GCM	Global Climate Model
GDP	Gross Domestic Product
IPCC	Intergovernmental Panel on Climate Change
IWMI	International Water Management Institute
IWD	Industrial Water Demand
IWA	International Water Association
MDD	Maximum Daily Demand
MDG	Millennium Development Goals
MWR	Ministry of Water Recourses
NMA	National Meteorological Agency
UNDP	United Nation development Programme
UNECA	United Nations Economic Commission for Africa
UNEP	United Nations Environment Programme
WHO	World Health organisation
WSP	Water Safety Plan
SCS	Soil Conservation Service

1 INTRODUCTION

Water is an essential commodity and access to safe water is a human right. In Addis Ababa, Ethiopia, the main part of the water is provided from open reservoirs near the city. The scope of this study is the water supply from the four reservoirs Gefersa I, Gefersa III, Legadadi, and Dire. Present and future conditions of these water sources and their water supply potential were studied. Furthermore was a systematic assessment regarding supplied water quantities from these sources under the impact of urban growth, climate change and climate extremes made. This was done by first hand observations and meetings, reviewing municipal and consultancy reports, as well as accessing meteorological, hydrological and demographical data during a field study in Addis Ababa.

The following three sections aim to provide some relevant background information that can be useful for the reader beforehand. Everything is not directly related to the study but touches issues that can make it easier to understand the challenges and nature of the context.

1.1 POPULATION GROWTH AND URBANISATION

By the year 2050 the world population is expected to exceed 9 billion, and people tend to move from the rural areas to urban ones. Cities all around the world are growing but the growth is most evident in developing countries. Demographic projections indicate that by the year 2030 as many as 75% of the world population could be living in urban areas (UN-Habitat, 2008). Ethiopia and the Addis Ababa region is not an exception of these trends. Ethiopia has a yearly growth rate of 2-3% which means that the country's population will double within 25 years (Ethiopian Embassy, 2011). Even though the city has an even faster growth rate (4-5%) than the country as a whole, Ethiopia has not yet been transformed to a country where the majority live in cities. Today 15% of the Ethiopian population is living in urban areas (CIA World fact book, 2011). These fast growth trends can be slowed down through behavioural changes such as increased family planning. At present, the average woman in Ethiopia get married when she is 16 years old, have 6 children and only 8 percent of the married women are reported using any form of birth control (Packard Foundation, 2007).

1.2 DEVELOPMENT

Regarding human development there is a lot to improve in Ethiopia. The country is placed 169 out of 177 countries according to the Human Development Index (UN Ethiopia, 2011). Ethiopia has an adult literacy rate of 36%, the access to clean water supply is 38% and the access to improved sanitation is 12% (WaterAid, 2011). The sanitation coverage rate is much higher in Addis Ababa with 75% of the population using pit latrines in 2009. Only 10 % of Addis Ababa got sewerage and many of the pit latrines will be disposed into the storm water drainage network. This water will move down to the rivers or be used in waste water irrigation schemes (Van Rooijen and Tadesse, 2009).

Ethiopia is a mountainous country and this has led to a very slow development of the infrastructure, even for a sub-Saharan African country. Infrastructure is a critical factor for development in a country. According to African Development Indicators from the World Bank, Ethiopia has 0.5 meter road per capita. This is one fourth compared to the average in sub-Saharan Africa (excluding South Africa) of 2.2 meter road per capita (Ministry of Water Resources, 2002). Worth mentioning is that there are big ongoing

infrastructural projects and that the infrastructure in Addis Ababa is much further developed than in other parts of the country.

1.3 HEALTH AND SOCIO-ECONOMIC SITUATION

Ethiopia is one of the least developed countries in the world, but the economy is growing, especially in the Addis Ababa region. The International Monetary Fund have given Ethiopia a large loan but agreed in 2005 to cancel the debts which led to a new start and a sounder economy for the country (CIA World fact book, 2011). The country's main economic activities (figures from 2004) are agriculture (46.3 %) and services (41.2%) and the present Gross Domestic Product (GDP) per capita is US\$1000 and growing at a rate of 7% in 2010 (UN Ethiopia, 2011). 85% of the employed workforce is working with agriculture, but the agricultural sector has been suffering from drought in 1985, 2003 and 2008 and the cultivation practices consist in most parts of hand labour (CIA World fact book, 2011).

As one of the least developed countries, Ethiopia has been struggling with famines and malnutrition. Ethiopia has a high rate of infant mortality (77/1000 in 2006), which is likely linked to limited access to improved water sources and subsequently diarrhoea. (Ministry of Water Resources, 2002) The following diseases are present in Ethiopia, many of them water related and indicated as high risk: diarrhoea, hepatitis A, typhoid fever, malaria, schistosomiasis and meningitis (CIA World fact book, 2011). With this in mind a primary health care coverage of 72% (in 2006) must be seen as low (UN Ethiopia, 2011).

1.4 OVEREXPLOITATION OF LAND

The overexploitation of land is a big issue in Ethiopia and it is mainly linked to poverty and high agriculture demands. With deforestation the natural buffering ability of the catchment is reduced leading to a more bulky runoff, agricultural land degradation and ecosystem problems. Trees are used for heating and for food preparation and due to poverty and lack of governance very few new trees are planted. In the literature land cover degradation is said to continue throughout this century and continue to be together with climate change the two major factors to global change (Olson *et al.*, 2008).

1.5 JUSTIFICATION OF THE STUDY

It can be hard to be conclusive about climate change effects but the world consensus is that the climate change will have a substantial impact on water resources both in a near and more distant future (Kundzewicz *et al.*, 2007). Even though there are uncertainties regarding the specific effects, estimations and assessments of the most likely scenarios must be done to provide water managers and engineers with at least an indication of what can be done at an early point and that is one of the things this study aims to contribute to. The topic of the study has been chosen due to the knowledge gap regarding how climate change and urban development will impact a city's water resources. Praskiewicz *et al.* (2009) write that: '... There is a need for more studies that examine the combined effects of climate change and urban development, because both types of changes are likely to occur in many basins, but their interactive effects are still not well understood.' According to the 'WHO Vision 2030 - Technology Projection Study' not many systematic assessments have been made regarding the potential impact of climate change on water resources (WHO & DIFID, 2010).

Another justification for this study is that it aims to contribute to the success of reaching the Millennium Development Goals (MDG). Additional constraints such as extreme events and climate change impacts on the already existing challenges in cities in the least developed countries can have large consequences. If this is not assessed and dealt with, its impacts on the water distribution could subsequently become a counter weight to the positive progress in reaching the MDGs, which aim to halve the poverty in developing countries by 2015. Especially goal 7.8 which aims to, by 2015, reduce the number of people without sustainable access to safe drinking water (UNDP, 2007).

1.6 HYPOTHESIS

The hypothesis for this thesis is that climate change will affect Addis Ababa surface water supply in a significant way within the next decades, but the major challenge of water will be due to population growth. Questions that arise are: What type of climate change impacts will have the largest effects on surface water supply? Within what timeframe do the water providers of Addis Ababa need to increase the supply rate to cope with future conditions? This study aspires to answer these questions.

1.7 AIMS

The overall goal of this study is to contribute to the present knowledge of how to make the water supply scheme in Addis Ababa less vulnerable to future anthropogenic changes.

The study aims to quantify and assess the present and future water provision from the four reservoirs Gefersa I, Gefersa III, Legadadi and Dire taking the impact of climate change, extreme weather events as well as increasing water demand into account.

1.8 SPECIFIC AIMS

New conditions due to climate change, population growth and other changes of the water demand could be seen as risks for the municipal water supply in Addis Ababa. By using available data (climatic, hydrological, water supply, social data and literature review), the specific aims of this study are to be able to:

1. Set up a water balance of the reservoirs to quantify water availability to the municipal water supply from the reservoirs for present and future scenarios.
2. Estimate the water demand in Addis Ababa for present and future scenarios.
3. Identify what effect previous extreme rainfall events have had on reservoir water levels and water distribution.
4. Make a vulnerability assessment of the water supply from the reservoirs under the impact of climate change and water demand change.
5. Make suggestions of appropriate measures.

2 BACKGROUND

The background literature review consists of present knowledge and recognised methods regarding climate change observations and projections, extreme events, open reservoirs, water distribution, water demand and vulnerability assessment.

2.1 CLIMATE CHANGE

Vast amounts of greenhouse gases from fossil sources are released into the atmosphere from anthropogenic sources. The scientific consensus is that this is causing the climate to change. Climate change is according to the Intergovernmental Panel on Climate Change (IPCC) Working Group II defined as ‘a statistically significant variation in either the mean state of the climate or in its variability, persisting for an extended period, typically decades or longer’ (IPCC, 2007).

There is visible evidence of climate change such as global average air and ocean temperature increases, glacial melting and higher sea levels. As an example the eleven years between 1995 and 2006 were among the twelve warmest years since the start of global temperature measurements (IPCC, 2007). The average temperature is expected to increase in all seasons throughout Africa. The temperature increase in Africa will even be 50% higher than the global average increase (UNFCCC, 2007).

Precipitation patterns have changed in many parts of the world. Significantly higher rainfalls have already been observed in north Europe, north Asia and on both American continents. In other parts of the world such as the Mediterranean, in southern Africa and parts of south Asia the precipitation has been reduced, and globally the likeliness of drought has increased (IPCC 2007).

The greatest climate change impacts are likely to be felt through water (WHO & DIFID, 2010). But it will also impact many other sectors and activities around the world; what scientist have at this point observed and society begun to feel is probably just the beginning of climate change (Howard et al., 2010). It is impossible to know in detail the nature of the climate change impact on a locality, despite the general trend. If using climate models it is possible though to get an indication of what future climate conditions will be like in a specific area.

2.1.1 Climate change in Ethiopia

According to the United Nation Development Programme (UNDP) ‘Climate Change Country Profiles’ there has been evidence of an already ongoing climate change in Ethiopia. The mean annual temperature has risen 1.3°C or 0.028°C per year between 1960 and 2006 (Figure 1). The number of ‘hot’ days and ‘hot’ nights has increased by 20% and 37.5% between 1960 and 2003 (‘hot’ is defined as 10% higher than average temperature for that area and period). The observed rainfall data does not show statistically significant trends regarding mean rainfall between 1960 and 2006 because of the fluctuating nature of the data set and the relatively short measuring period (McSweeney et al., 2007).

The UNDP Ethiopia Profile report uses climate change projections made by Global Climate Models (GCMs) to make climatic forecasts for Ethiopia.

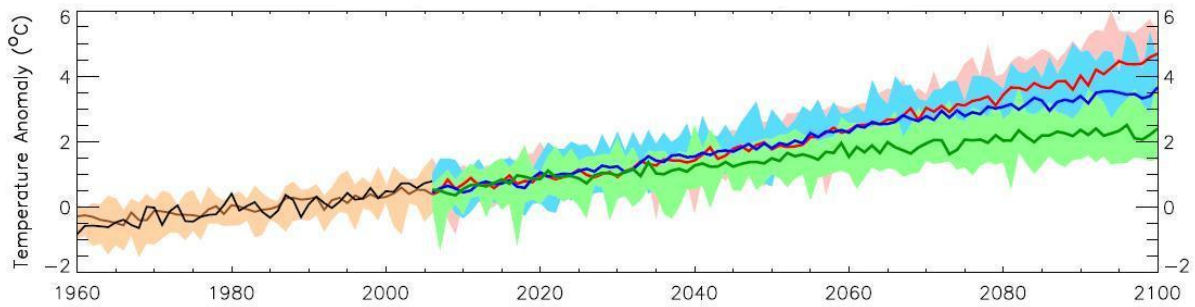

Figure 1. The annual mean temperature increase in Ethiopia. The pink part before 2006 is observed temperature data and the green, red and blue temperature lines present forecasted temperatures using different models. The broader coloured sections close to the lines are error margin for each curve (McSweeney et al., 2007).

The predicted future trend regarding rainfall patterns show general increase in annual rainfall, especially during October to December. The rainfall amount by the 2090s is predicted to increase within the range of 10% to 70% in Ethiopia (McSweeney et al., 2007).

There is no empirical evidence in historical data of any change in annual rainfall, even with long term rainfall data at hand (Conway et al. 2004). The future prediction of short term change in annual rainfall is uncertain. Figure 2, which is representing the global predictions of annual-mean rainfall changes for 2020, visualizes these uncertainties. White areas indicate that less than 66% of the models used in this projection agreed on sign. But this map still indicate that the Addis Ababa region will have higher mean rainfall compared to the reference years (1979 to 2001) (WHO & DIFID, 2010).

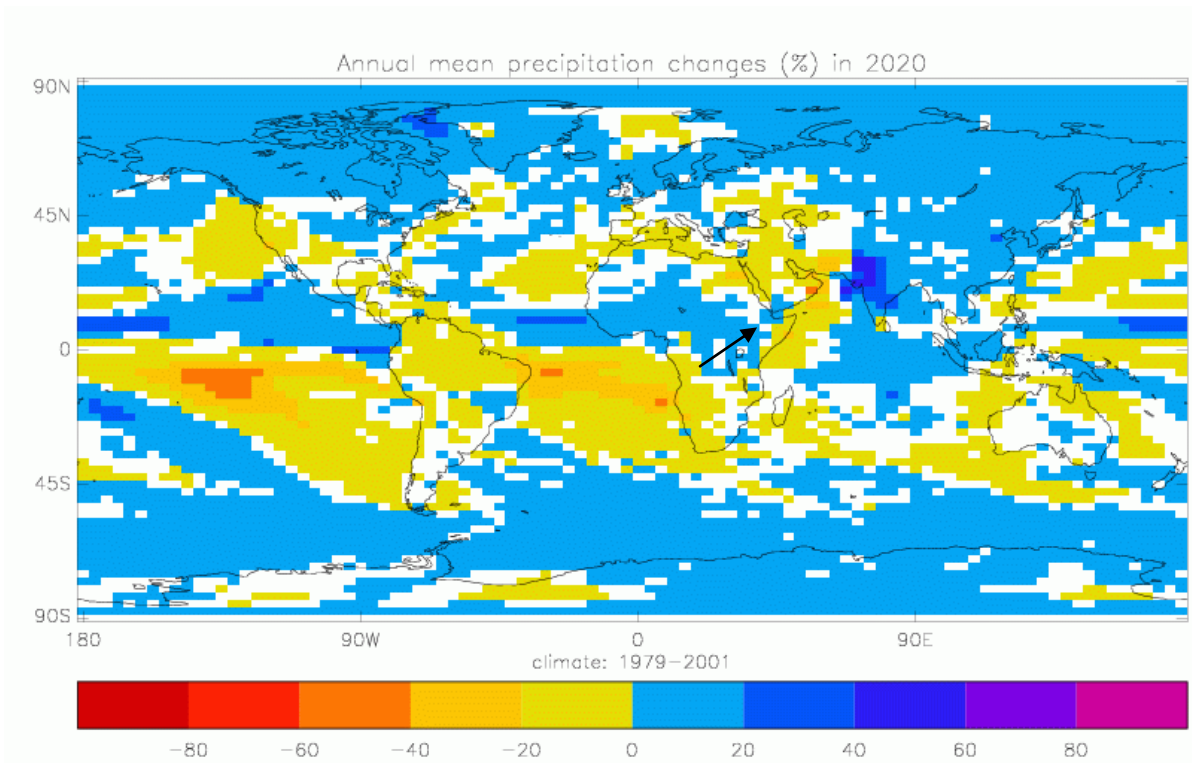

Figure 2. Predictions of the global percent change in mean rainfall by 2020 compared with a dataset from 1979-2001. The blue-purple colours indicate precipitation increase and yellow-red colours indicate precipitation decrease. In the white coloured areas the change is too uncertain (WHO & DIFID, 2010).

In the UNDP report the projected median increase of rainfall for 2030 was 3% for the Addis Ababa region but minimum and maximum scenarios differed between -3% to 8% monthly change, see Figure 3 (McSweeney et al., 2007). The climate change effect on rainfall intensity and dry and wet extreme events is in the extreme event section.

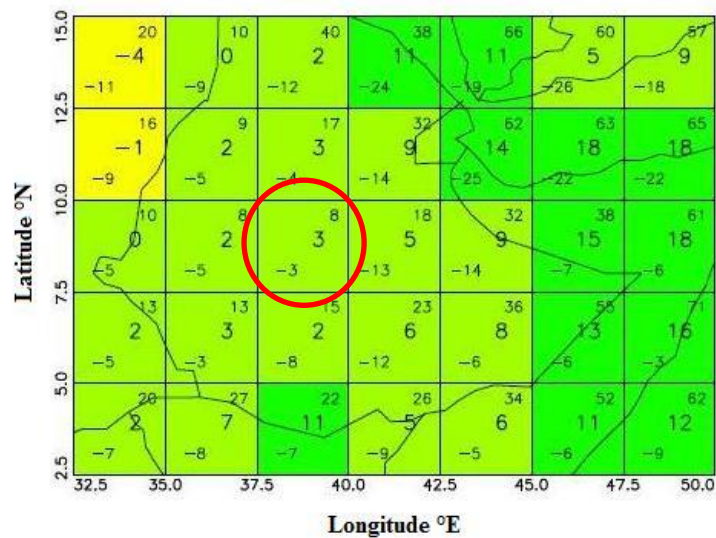

Figure 3. UNDP projection over Ethiopia for 2030 regarding rainfall percentage change related to data from 1970 to 1999, minimum, maximum and median values are shown in each square. The red circle marks the studied area (McSweeney et al., 2007).

2.1.2 Climate models

Predictions of the expected climate changes through modelling can help plan for the future and also be a guide to find appropriate adaptation strategies (WHO & DIFID 2010). GCMs are used for such predictions and the concept is illustrated in Figure 4. They are 3-dimensional models and have been the base for all the predictions used in this report. They are relative coarse models and if the purpose is climate impact assessments on a specific locality there is a need if an interlinked regional model over the area of interest (IPPC, 2011).

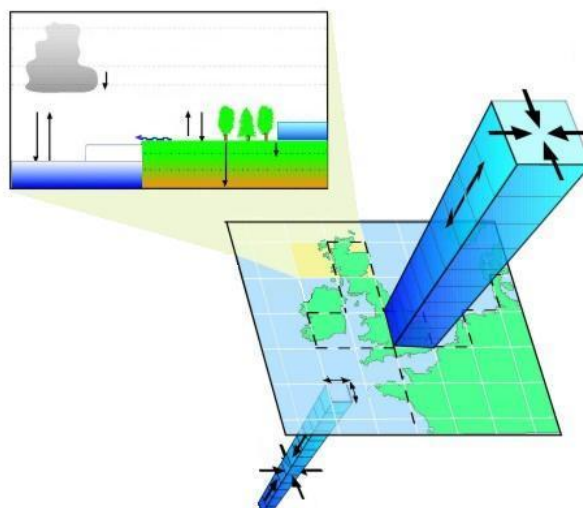

Figure 4. An illustration of how the GCM is divided into 3-dimensional segments of land, air and water (Viner, 2002).

If there is need of even higher resolution, which is the case for areas with for example very heterogeneous land cover or topography, modellers use various downscaling methods. Many different GCMs are used in downscaling to get a more reliable result (Wilby et al., 2004).

Even though these models are strong the result can be quite variable depending on how certain aspects are modelled. Uncertainty in climate simulations with GCMs can be linked to different feedback mechanisms (IPPC, 2011). The uncertainties can accumulate when the data is further processed with downscaling; this is one of the reasons why results often are presented in broad intervals (Wilby et al., 2004).

2.2 EXTREME WEATHER EVENTS

During the summer of 2010 people around the world could see the seriousness of an extreme weather event, the flooding in Pakistan was devastating for that society and led to the death of many. The weather is the result of many parameters and their dynamic interactions. Occasionally there can be anomalies of what is considered normal for an area, such as extreme rainfall amounts, extreme rainfall intensities and extreme temperatures. For an event to be called extreme, it should be less than 5% probability for it to occur. Return periods of extreme events, even such that has not yet occurred, can be predicted based on previous weather data, assuming a certain distribution of the anomalies. The larger the return period is, the more extreme is the weather.

According to the ‘WHO Vision 2030 - Technology projection study’ (WHO & DIFID, 2010) the climate change will not only affect the average weather (climate) but also result in more extreme weather. Such change in the variability of the weather is significant in many ways for water resource managers (Praskiewicz, 2009). Other studies have also shown that extreme weather events will become more frequent and severe in the future. It will then result in increasing risks of drought and flooding, leading to increased risk to health and life (Few et al. 2004 and Christensen et al. 2007). More floods will also increase the soil erosion, affecting the water infrastructure and quality. More droughts will affect the water availability and its quality (WHO & DIFID, 2010). The consequences will hit people hardest in a developing country context. Poor housing structures and poor drainage systems can be disastrous if there is a severe flooding and these are problems that can be found in Addis Ababa (UN-Habitat, 2008). The climate prediction models used in “UNDP Climate Change Country Profile of Ethiopia” are indicating an increase of intense rainfalls, or as they called it, “heavy events”. The increase in heavy event rainfalls is predicted to be approximately 7% in the 2090s compared with the reference data (1970 to 1999) (McSweeney et al., 2007).

The left part of Figure 5 below shows a clear global trend toward a higher frequency of dry events compared to the last century. The right part shows the spatial distributed change from 1900 to 2002 regarding how much drier or wetter specific areas are, using the Palmer drought severity index (WHO & DIFID, 2010). This index is a soil moisture algorithm commonly used by U.S. government agencies to indicate coming droughts for triggering relief programs. It was first developed in 1965 using a supply-and-demand concept and the water balance equation (Hayes, 2011). There seems to be a trend in the East African highlands where Addis Ababa is located (arrow) towards more wet events. This is opposite the general trend in the world.

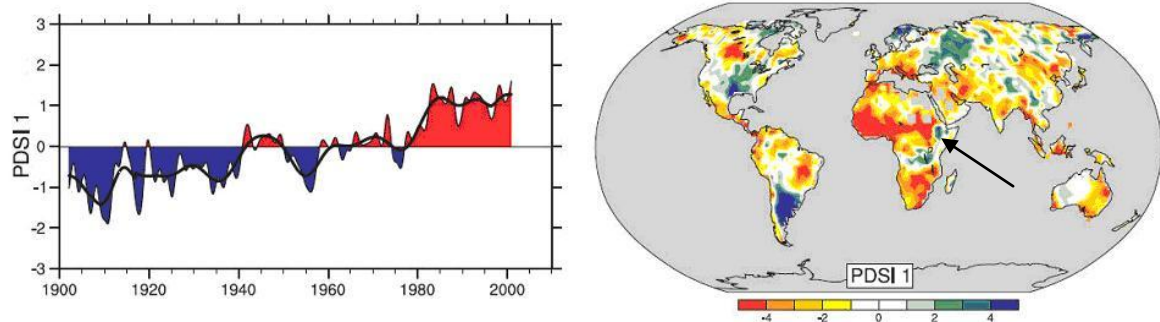

Figure 5. To the left is the global trend of dryness according to the Palmer drought severity index (PDSI). The index uses 0 as normal and the higher the number is the drier was that specific year. To the right is the spatial distributed PDSI change from 1900 to 2002 (WHO & DIFID, 2010).

The intensity of the rainfalls is also likely to increase and the trend is clear both in the world and in the Addis Ababa locality (Figure 6).

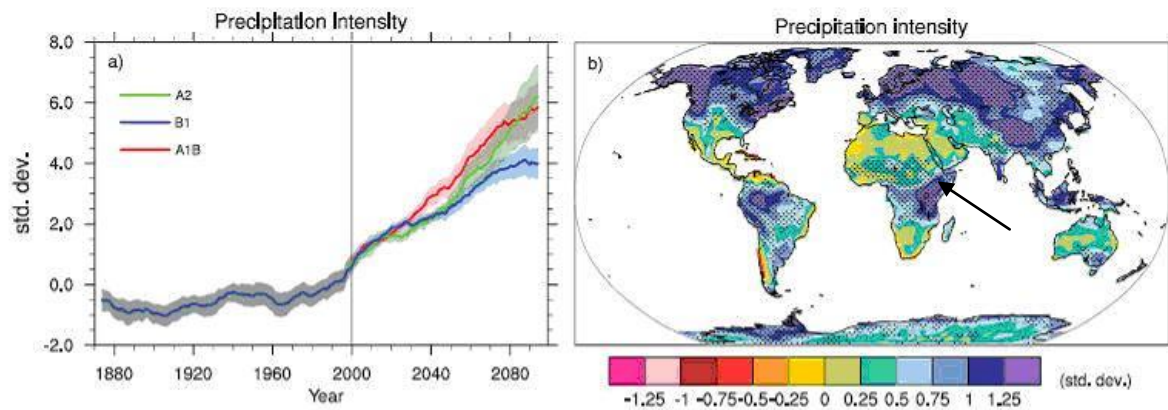

Figure 6. To the left is the projected standard deviation in global average precipitation intensity for a low, middle, and a high scenario presented compared to the year 2000. To the right is the spatial distribution of the middle precipitation intensity scenario, looking at the standard deviation between two 20 year means (2080–2099 and 1980–1999) (WHO & DIFID, 2010).

The climate change impact on rainfall patterns can have a great impact on water resources and water supply and should therefore be considered specifically (WHO & DIFID, 2010). There are also other more complex ways in which the water situation will be affected by extreme events. To mention one, droughts and floods tend to increase migration and urbanisation, subsequently causing further constrain on the urban water supply systems (WHO, 2009).

2.3 RESERVOIRS

The history of water infrastructure to cope with variability in water availability dates back to the ancient times. Over time this has developed into many water management options, such as dams and water reservoirs used for drinking water storage, flood control, hydropower generation or irrigation for cultivated land. This is done to maintain community activities and safeguard public health during extreme hydrological events (Muller, 2007). Reservoirs are most commonly established by constructing a dam across a river, which is also the case for all the reservoirs outside Addis Ababa. There are many reservoirs formed by dams in the world, both large and smaller ones. With the International Commission of Larger Dams definition of 'large' based on reservoir capacity and dam embankment dimensions, there are about 40 000 large dams and estimated 800 000 small dams in the world (UNEP, 2000). The dams used for water distribution to Addis Ababa are all large.

2.3.1 Evaporation and seepages

Open reservoirs created in the landscape are affected by natural hydrological processes such as evaporation of water and water seepage to the surrounding ground as well as through the dam structure. By establishing the reservoir in an appropriate place and following good construction practices, seepage can be reduced. Losses through evaporation are in some areas of major significance and can be as much as several meters per year (Britannica, 2011).

The extent of the evaporation depends on several parameters but can be represented by the Penman equation. Linacre (1993) published an article about a simplified version for evaporation estimations which is used in this study (see details in the water balance section).

2.3.2 Dam life expectancy

The performance of the reservoir can also be reduced by sediment depositions. This occurs because the flow velocity decreases when the water passes through the reservoir. The consequence is reservoir volume reduction, and the maximum life expectancy of a reservoir is therefore in general limited to 100 years (Britannica, 2011). The design of a dam is based on the, at that time, available demographic and hydrological data, but with the present evidence of climate change, such design could be insufficient if supply and demand condition changes (O'Hara et al., 2008). One way of adapting if the reservoir is inadequate is to expand the reservoirs, if it is topographically and hydrologically feasible (Graham et al., 2006).

2.3.3 Climate change and reservoirs

According to a report from United Nations Environment Programme (UNEP, 2000) called 'Climate Change and Dams', dams have a double role regarding climate change. They can be a source of green house gases; both carbon dioxide and, if the water at the bottom of the reservoir becomes anaerobic, they could also emit methane gas. Another aspect of dams is that they can be important as flood control infrastructures, and if rainfall intensity increases due to climate change such infrastructure can save lives. The same report states that dams themselves are affected by climate change. Increased temperature increases the evaporation and increased rainfall intensity will increase the sediment transport to dams. Both of these impacts reduce the capacity of the dam (UNEP, 2000).

2.4 WATER DISTRIBUTION

2.4.1 Piped water supply

The water distribution from the reservoirs in Addis Ababa is piped water supply. The water supply includes utility managed supplies, community managed supplies, and tap stands. These schemes often have capacity and management problems even without any climate change effects, but climate change could amplify these problems in the future. According to various scientists climate change is likely to cause some water supply issues in the future, and at some places it already is (Bates et al., 2008; Evans & Webster, 2008; Hedger & Cacouris, 2008, cited in Howard et al., 2010). The degree and timeframe will vary but the sector is likely to face problems and there is a need to know more about how these problems can be addressed.

2.4.2 Increased average rainfall

If the climate change result in increased average rainfall, which is a likely scenario for Addis Ababa, the piped water supply can be facing problems, especially since it is a surface water source system (Howard et al., 2010). The same report states further that a potential problem with flooding can be the reduction of water quality through ingress in distribution pipes of flood water or overflowing sewerage water. Another potential problem can be that groundwater levels rises in the future due to increased rainfall, subsequently leading to polluted water ingress. An example of this is the flooding of Dhaka city, Bangladesh, in 1998, where the supply suffered from cross contamination with flooded sewerage ingress into not enough maintained pipes. Many household reservoirs that were standing on ground level were also contaminated when they got submerged (Nishat et al., 2000).

2.4.3 Increased rainfall intensity

Increased rainfall intensity is also a potential threat to the water distribution. A very intense rainfall leading to high runoff levels can cause soil erosion, and capacity and water quality problem for the treatment plant due to sedimentation transport. Another problem with large intensity is infrastructure damage, especially if there is a flush flood (Howard et al., 2010).

2.4.4 Decreased average rainfall

If the climate changes result in lower levels of rainfall then the main vulnerability regarding piped water would be water deficit, especially for systems that take water from on surface sources (Howard et al., 2010). When the supply decreases due to low water flows the often used intermittent management approach will result in low internal pressure in pipes followed by an increased risk of dirty surface water ingress (Persson, 2009).

2.4.5 Energy dependency

Piped networks are dependent on energy for treatment and distribution of the water. This must be seen as a risk, especially in areas where there is a shortage of electricity. Climate change effect could cause disruptions in energy supply which subsequently would lead to water distribution problems. Gravity feed schemes would be more resilient to these risks (Howard et al., 2010).

2.4.6 Distribution vulnerability

In general, utility-managed piped water supplies should, if personnel and financial resources are available, be considered to have high adaptive capacity. This is in line with a recent questionnaire based study among urban water managers in developing country contexts (Howard et al., 2010). In the study, piped water supplies were perceived to be the supply method least vulnerable to climate induced changes in rainfall patterns, compared to methods such as hand pumps or protected springs. A criterion for this to become true is that those in charge will develop and implement risk assessment tools, such as the Water Safety Plan (WSP) approach, including climate change impact risks for the specific context (Howard et al., 2010).

2.5 WATER DEMAND

2.5.1 Water scarcity

Even though the coverage of improved water sources in the world are as high as 94% in cities, this percentage has not increased since the 1990s (WHO & UNICEF, 2010). This is perhaps due to the fact that urban water management in these contexts is very challenging. There are indications that within a foreseeable future this development, which is not rapid enough, could even turn into water scarcity in many urban areas due to reduced access to safe water (Mintz et al., 2001). This is a probable scenario for Addis Ababa if not the right measures are undertaken (IWA, 2010).

According to ‘Global environmental outlook 2000’ from United Nations Economic Commission for Africa (UNECA, 1999) many African countries will face water stress or water scarcity in the coming decades. They define water stress as less than 1700 m³/capita of water annually and defining water scarcity as having less than 1000 m³/capita of water annually. On the map in Figure 7 you can see the situation regarding water availability in Africa. It indicates that Ethiopia is just on the border between stress and scarcity.

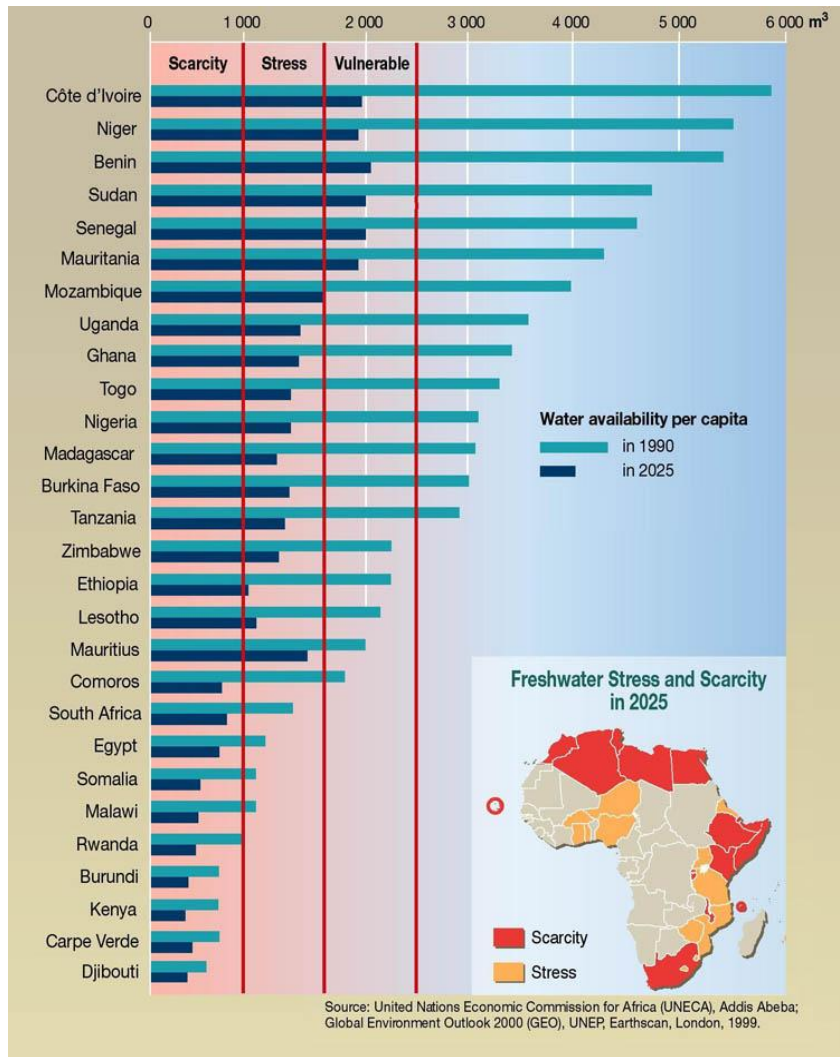

Figure 7. Water availability per capita for African countries (IWMI 2007a).

Water scarcity is not only related to the amount of water available, but also to the number of people that share that available quantity of water, and if the available water can become accessible. There are many reasons for not having sufficient water. According to Figure 8, a map from International Water Management Institute (IWMI, 2007a), the potential water scarcity in Ethiopia would mainly be caused by economic limitations.

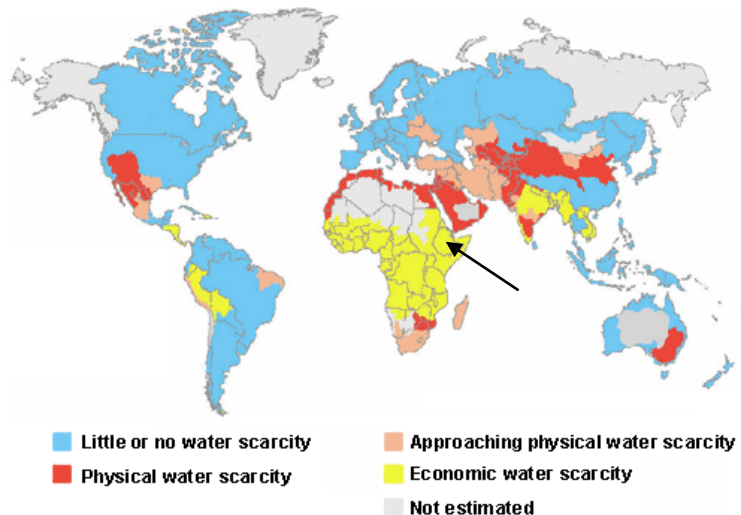

Figure 8. Map from IWMI (2007a) illustrating different types of water scarcities in the world.

The economic water scarcity is caused by an inability to put sufficient infrastructure, regarding water supply, in place to cope with high birth rates and urbanisation (IWMI 2007b). The growing cities in the world will have problems to find potable water resources within an economically viable distance for all. On top of that the demand per capita will increase, as consequence of increases in economic growth (purchasing power) and new habits among those who the water is distributed to (Howard et al., 2010). The increased water consumption that comes with economic growth is mostly due to more frequent use of WC-toilets and the increased demand for various industrial purposes (MWR, 2002).

2.5.2 Quantifying water demand

An appropriate way to quantify the water demand is to use Maximum Daily Demand (MDD), including system losses. This is done by using the Domestic Water Demand (DWD), which is the daily per capita water consumption if the water is not limited. In water limited contexts, such as Addis Ababa, the actual demand is greater than present consumption. Domestic water is according to WHO (2008) defined as ‘water used for all usual domestic purposes including consumption, bathing and food preparation’. DWD is estimated by using standard figures for domestic needs (MWR, 2002). Gleick (1996) recommends at least 50 litres per capita and day. According to WHO (2003) this is not enough; the optimal access should be more than 100 litres per capita and day.

There are other demands in an urban context such as Commercial and Institutional Water Demand (CIWD). This is the water needed for public and commercial facilities. CIWD is often linked directly to the size of the population, for cities as large as Addis Ababa the CIWD can be estimated to 10 % of the DWD (MWR, 2002).

Industrial Water Demand (IWD) must be taken in account as well and a reliable number would be 30% of the DWD for large cities. With these above mentioned demands it is possible to estimate the Average Daily Demand (ADD) per capita (MWR, 2002).

Water consumption varies in all contexts depending on season, climatic conditions and the time of the day. The MDD in Addis Ababa has been estimated by the Ministry of

Water Resources (MWR) in Ethiopia to be 1.15 times the ADD. This is not an exact number but it is used for demand estimations (MWR, 2002) Presently Addis Ababa Water and Sewerage Authority (AAWSA) use 110 litres per capita per day as MDD (AAWSA, 2011).

2.6 VULNERABILITY ASSESSMENT

2.6.1 The need of research

There are several reports that call for vulnerability assessments regarding climate change impacts (Howard et al., 2010 and UNEP, 2000). They call for robust climatic and hydrologic data coupled with rigorous assessments of the risks or vulnerabilities. 'WHO Vision 2030 - Technology projection study' claims that surprisingly little has been written and in the papers that have been written very general conclusions are drawn. At the same time research on climate change seems to be thriving and an often discussed topic in public opinion. There seems to be a discrepancy of want of such research and the feasibility to conduct such research.

2.6.2 Water Safety Plan

A water supply vulnerability assessment should according to the Drinking Water Inspectorate (2005) have a holistic approach due to the many stakeholders involved, and the risks. There are risks regarding water quantity and quality as well as infrastructural and environmental damage. Bartram et al. (2009) state that 'using the WSP approach to look at vulnerabilities at each stage of the system for climate-induced risks may be an effective approach to understanding climate impacts and adaptation options'. The WSP is a risk assessment framework developed by large stakeholders in the water sector and is promoted by WHO since the beginning of the 2000s. The WSP uses the multiple barrier approach and the idea is to assess systematically from source to user. The WSP approach is recommended for risk assessments in the 'Guidelines for drinking quality'. Even though this study will not do a full assessment, which would include a framework for monitoring and safeguarding constant point-of-use water access, the approach can be used for a part of a system for vulnerability assessment (WHO, 2008).

3 ADDIS ABABA - AREA DESCRIPTION

3.1 CLIMATE

At latitudes of 9°N Addis Ababa's climate should be typically tropical but due to the high altitude it is much cooler. Mean annual temperature is around 15-20°C in this region. There are seasonal rainfalls, the main one is during June to September called "Kiremt" and a smaller one is in February to April called "Belg". These rains are mainly driven by the oscillating Inter-Tropical Convergence Zone (McSweeney et al., 2007).

The average rainfall is around 1200 mm/year. Normally about 70 % of the rain falls in the 'Kiremt' (AAWSA, 1995). According to McSweeney et al. (2007) the climate variability between years that exist is linked to the 'El Niño Southern Oscillation Warm phases' causing reduced rainfall in the 'Kiremt' and increases rainfalls in the 'Belg' during periods. There have been climatic data recorded in Addis Ababa for over 100 years, Figure 9 is the rainfall record presented in Conway et al. (2004).

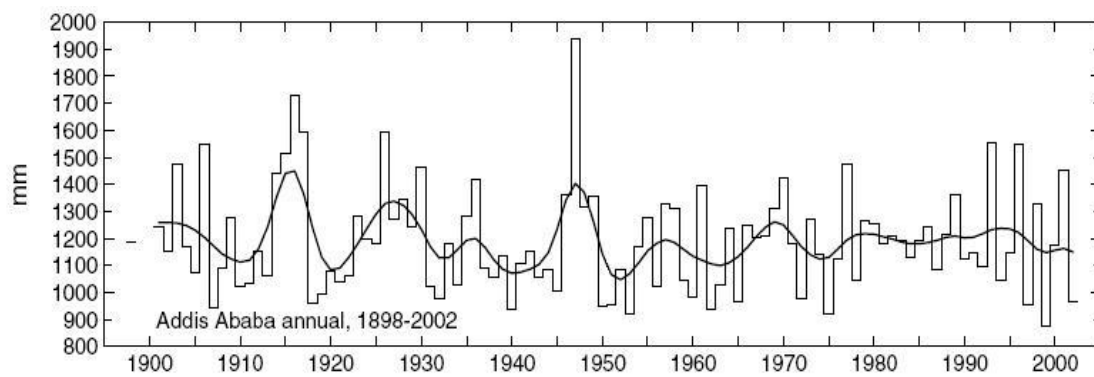

Figure 9. Rainfall measurements in Bole meteorological station (mm/year), 1898 to 2002 including a 10 year filter. Note that the y-axis starts at 800 mm (Conway et al. 2004).

The area is not very windy, it has approximately an annual average of 0.5 m/s and the average amount of sun hours is 6.5 (AAWSA, 1995b).

3.2 GEOGRAPHY

The city of Addis Ababa is located in the centre parts of Ethiopia, on the southern slopes of the partly forested Entoto ridge. South of the city is the lower land of Great Rift Valley with its savannah landscape (AAWSA, 1995a). The Entoto ridge is the watershed between the large Abbay/Blue Nile basin (199,812 km²) to the north and Awash river basin (112,700 km²) which is the basin Addis Ababa is located in (UNEP/UNESCO/UN-HABITAT/ECA, 2003). The basins can be seen in Figure 10. Through Addis Ababa runs the Big and the Little Akaki river and the Kebena river, they join south of the city and later join with the larger Awash river. Addis Ababa is surrounded by mountains in all directions except south and is located on altitude of between 2000-3000 meters above the sea level depending on where in the city you are.

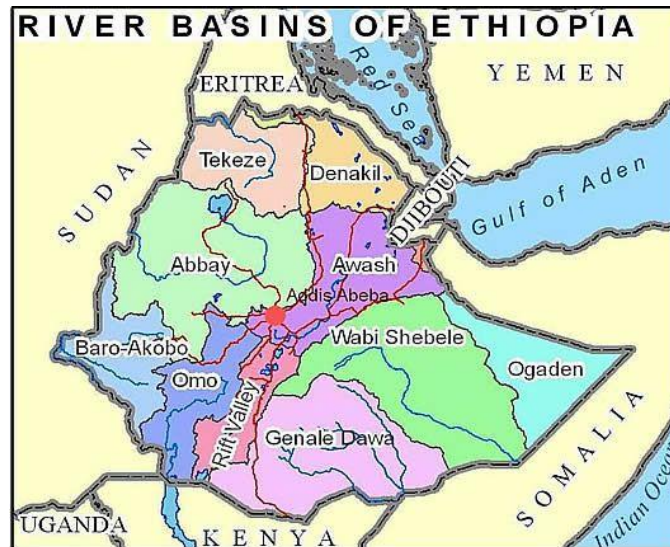

Figure 10. Map showing the river basins of Ethiopia (Gadaa.com, 2011).

3.3 URBAN GROWTH

Addis Ababa has undergone a transformation from being a fairly small city of 500,000 citizens to more than 3 million the last 60 years, and the projected population growth indicates that it will double if not triple in size by 2030 (Van Rooijen and Taddesse, 2009). The city has grown in an unforced and unstructured way and has not had documented urban planning until recently which has put constraints on the water supply system (Crampton, 2005).

3.4 WATER SUPPLY

When Addis Ababa was founded the location where it stands was chosen partly because of the natural springs at the site. The city grew and they needed new sources and in 1938 they built a plant for treating the water from one of the nearby rivers. The city kept growing and the first dam was constructed in 1944 (Gefersa I) to cope with the growing demand. During the 50s many springs deteriorated in quality and were taken out of service. In the 1960s the Gefersa treatment plant was built, having a capacity of 30,000 m³/day and in 1966 another dam (Gefersa III) was built both to increase capacity and to function as a sediment trap. From Gefersa treatment plant went two transmission pipelines each 400mm to the distribution reservoirs in Addis Ababa. Figure 11 are pictures of Gefersa reservoir and treatment plant.



Figure 11. To the left is the dam structure in Gefersa I and to the right are parts of the Gefersa treatment plant (AAWSA 1995a).

The next big step was the Legadadi Dam, treatment plant and transmission pipeline, built 1970. This lower located dam needed a pumping system for the water distribution. During the 80s the Legadadi treatment plant capacity was increased from 50,000 m³/day to 150,000 m³/day and a second transmission pipeline was built. The engineers knew already at that time that these sources would only be sufficient up until 1992 due to the growing population in Addis Ababa. They looked at different sites for building the next great dam, something that could provide water up to 2020. Due to various political and economical instabilities this project was postponed (and is still so) and two emergency projects had to be implemented instead, the construction of the Dire dam and the Akaki well field. (Sime, 1998) Together with the construction of the Dire dam was the Legadadi treatment plant further improved to the capacity it has today of 165,000 m³/day. The Akaki well field has a capacity of 43,000 m³/day. (AAWSA, 2011) All mentioned surface water sources and the well field can be seen in Figure 12.

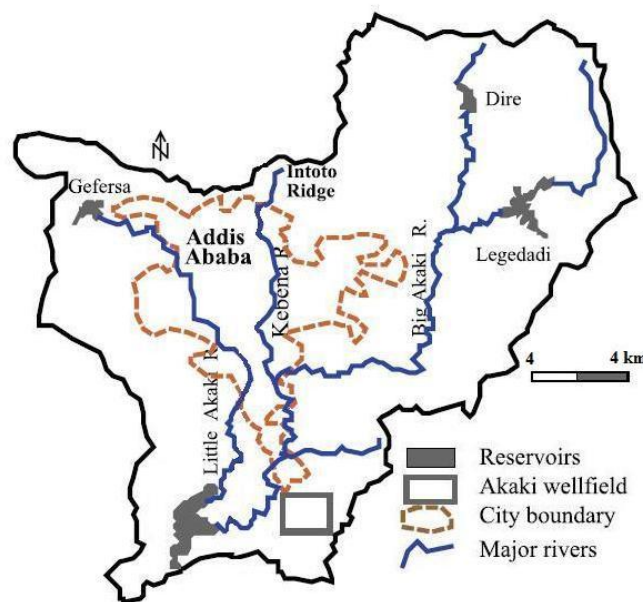

Figure 12. Surface water sources surrounding Addis Ababa are marked with gray and the well field is located within the gray square. Map taken from Ayenew et al. (2008).

At present 14% of the water supplied to Addis Ababa is from the Akaki well field, which is located about 10 km South of Addis Ababa, 21% (63,000 m³/day) of the water is from other scattered wells and the remaining protected springs. The 65% (195,000 m³/day) left is provided from the four above mentioned open reservoirs. These are located in the surrounding of Addis Ababa, all within the Awash basin. The Gafersa dams I and III are located about 20 km northwest of Addis Ababa and the Legadadi and Dire dams are located about 30 km Northeast of Addis Ababa. (AAWSA, 2011) Table 1 present the most important facts about the four dams.

Table 1. The most important facts regarding the reservoirs (AAWSA, 2002, 1995a, 1995b, 1982).

	Legedadi	Dire	Gefersa I	Gefersa III
Construction year	1970	1999	1944	1966
Capacity (10^6 m^3)	40	13	7	1
Runoff ($10^6 \text{ m}^3/\text{year}$)	70	40	27	Within Gefersa I's
Surface area (km^2)	4.0	1.3	1.4	0.4
Dam size (mxm)	22x600	46x665	15x150	18x220
Catchment area (km^2)	225	72	56	Within Gefersa I's
Supply rate (m^3/day)	127 000	38 000	30 000	Only to Gefersa I
Notes		Used first half of the year		Used for sedimentation purpose

The piped water supply in Addis Ababa is operated publicly by the Water Supply and Sewerage Authority (AAWSA) supplying in average about 80 litres per capita per day to their customers (AAWSA, 2011). The water is still, as it was when constructed, supplied from the Gefersa treatment plant in two 400 mm pipes but for Legadadi the 900 mm pipes have been replaced with one 1200 and one 1400 mm pipe. The Gefersa distribution uses both pressured and unpressured pipes and Legadadi only pressured pipes. The Gefersa water is distributed in the north-west parts of Addis Ababa and the water from Legadadi is distributed in the east and the central parts of the city. The south parts get the water from the well field. The water is distributed via distribution reservoirs to household connections and public taps and about 5000-9000 new connections are established annually (AAWSA, 1993).

The water supply system has water losses. According to one of the senior engineers is 20% of the water lost through physical losses. This percentage is annually calculated by a developed simulation tool from International Water Association (IWA). 14.7% is not accounted due to commercial losses including metering error and illegal connections. 2.2% is unbilled metered consumption. And the main problem according to that engineer is the aged supply system pipes. Some are up to 40 years old.

4 METHODOLOGY

This study is based on qualitative data, quantitative data and calculations that have been available and appropriate for the assessment of water supplies from surface sources. The methodology behind is described under following topics: available data, calculations made and vulnerability assessment.

4.1 AVAILABLE DOCUMENTS AND KEY INFORMANT MEETINGS

To get a broader view of issues that affects the water supply scheme from the reservoirs and to fill in gaps of necessary data or make assumption, a part of the study was to review municipal water authority documents (which was available on-site in the AAWSA library). This proved to be an essential part of the study and the consultancy reports were very important due to the lack of runoff data and gave a good insight to what issues the water supply from surface sources have had. The library resource also had document on extreme events mainly focusing on previous rainfall data and this together with analysis of the collected rainfall data from the meteorological agency became the extreme event study. Only rainfall was considered for the extreme event review because it is thought to be the main impact on water distribution. (WHO & DIFID, 2010)

As a secondary activity to confirm the findings and ask questions, appointed meetings were held with two senior engineers each at two occasions at the AAWSA headquarter. The meeting with the first senior engineers who was an expert on the reservoirs and the distribution from them was held to collect information regarding the dams, the raw water treatment and the catchments of interest. The second meeting was held with an expert on water distribution, water losses and water demand. The follow up meetings a few weeks afterwards were held to confirm the calculations and the hazardous event scoring.

4.2 WATER BALANCE CALCULATION

During the three month field study in Addis Ababa quantitative data was collected from AAWSA, National Meteorological Agency (NMA) and MWR. The collected data was the base of the water quantity calculations. The water availability was estimated by using the water balance of the reservoirs. Further data from internet sources from MWR (2002) was used to make estimations of water demand of the city. The quantities were estimated for the present situation and for two future horizons, 2020 and 2030. Likely changes in average runoff and temperature were taken into account as direct climate change impacts on the water supply from the reservoirs.

4.2.1 Water balance model of the reservoirs

In this study the average change in storage is assumed to be zero. The inflows to the system are runoff from the catchment area (Q_{in}) and direct rainfall (P) and the outflows are spill (Q_{sp}), treatment plant intake (I), seepage (Q_{se}) and evaporation (E).

$$Q_{in} + P = Q_{sp} + I + Q_{se} + E \quad (1)$$

To get the necessary data for the water balance many different sources were used and all flows except spill were able to be estimated. The spill could subsequently be derived from equation 1, assuming that the dams are filled up once a year and that the management of the dams are similar from year to year. Following section is a description how the variables were estimated and where the data came from.

4.2.2 Runoff

This was the main issue because none of the inflows to the dams were gauged for a longer period of time. The same problem had faced consultants earlier even when the Dire dam was built during the late 1990s. In this study the average value of inflow estimations of all following methods from different consultancy reports were used.

A method called ‘regionalization method’ was used by the consultants using estimated runoff equivalents per area from a similar and nearby catchment. Then they applied that specific per area runoff for all the studied catchments assuming that the characteristics of the nearby catchment are scientifically the same as the studied once. The recorded flow used was from the Munger River near Chancho, north of the Entoto ridge.

Another method used was a regression method which used the regionalization method but did also take into account the fact that smaller catchment areas can give higher yield or runoff per area. In this case they used the eight closest catchments and by using linear regression getting the runoff per area dependent of catchment size. Then they calculated the specific runoff for each studied catchment depending on its size.

The third method used was a hydrological model called ‘Soil Conservation Service’ which is developed by the United States department of agriculture and has been used to estimate runoff in many catchments in Ethiopia. The model uses hydrological processes such as interception, evaporation, transpiration and infiltration to estimate runoff (AAWSA, 1995).

The future change of rainfall and subsequently inflow are uncertain even though the most likely scenario is increased rainfall leading to increasing inflow levels for the study area (see the climate change section in the literature review). To be able to quantify the runoff it is assumed to change in the same way as the rainfall. This study has used three likely scenarios 0%, 5% and 10% in accordance with Figure 3 as possible inflow-changes by the years 2020 and 2030.

4.2.3 Direct rainfall

The direct rainfall on each dam surface was calculated through using rainfall data and surface areas of the dams. Rainfall data was received from the meteorological station near Bole airport, which is known as the best in Ethiopia and is also the one the author was recommended to use by NMA staff. The surface data for the Gefersa dams and the Legadadi dam was found in one of the older municipal documents (AAWSA, 1982). The surface area of Dire dam was graphically estimated from maps in one of the consultancy reports. (AAWSA, 1995) Future values of 0%, 5% and 10% will be used for rainfall change in accordance with Figure 3 as possible inflow-changes by the years 2020 and 2030.

4.2.4 Treatment plant intake

In a water treatment process some of the intake water is left in the residual product, this water is seen as the process loss. The intake flow was calculated ‘backwards’ from the daily water volume distributed from the treatment plants and the process loss factor given in one of the consultancy reports of 1.1 was used (AAWSA, 2002). No change due to climate regarding the treatment plant raw water intake is assumed.

4.2.5 Seepage

There are two types of seepage, infiltration through the bottom of the reservoir and leakage through the dam structure. The only reservoir that seepage has been estimated for is Dire dam. The Dire dam bottom leakage per square meter was used for the other sites as their bottom seepage assuming similar geo-hydrology. No change due to climate regarding treatment plant intake was also assumed.

4.2.6 Evaporation

Stored water evaporates from open reservoirs. In the Addis Ababa area where the air is dry and the climate is fairly hot, significant water quantities could be lost and evaporation should therefore be taken in account. To calculate the evaporation the simplified Penman equation (equation 2) was used. This equation was developed for locations where the data availability is insufficient, as it is in Addis Ababa (Linacre, 1993). A simplified Penman equation by Lincacre (1993), where E_0 = lake evaporation (mm/month), T = air temperature ($^{\circ}\text{C}$, weighted temperature), h = altitude (m), R_s = solar radiation (W/m^2), $F = 1.0 - 8.7 \cdot 10^{-5}h$, u = wind speed (m/s) T_d = dew point temperature ($^{\circ}\text{C}$).

$$E_0 = (0.015 + 0.00042T + 10^{-6}h) (0.8R_s - 40 + 2.5F \cdot u(T - T_d)) \quad (2)$$

According to Linacre (1993) appropriate temperature estimations can be made by weighting the max and min temperature (equation 3). Dew point temperature has been obtained from air temperature and relative humidity according to the August-Roche-Magnus approximation (equation 4) where $a = 17.271$, $b = 237.7$ ($^{\circ}\text{C}$) and $\text{RH} = \text{relative humidity (\%)}$.

$$T = (0.6T_{max} + 0.4T_{min}) \quad (3)$$

$$T_d = bG / (a - G) \text{ where } G = aT / (b + T) + \ln(\text{RH}/100) \quad (4)$$

The future change in evaporation is presumed to be linked to rising average temperature. There could be other parameters affecting the evaporation that are changed with climate changes such as average numbers of sun hours but this is not a parameter used in this simplified Penman equation. The temperature change is taken from the UNDP country report on climate change (McSweeney et al., 2007).

4.3 WATER DEMAND

Water demand or maximum daily demand as it is called in the literature review is affected by physiological, demographic, economic and social parameters. What has been taken into account in this study is the population of the distribution area, average daily demand and supply losses. See the water demand section (2.5.2) in the literature review for a more careful description of how this has been calculated and below it is summarized.

4.3.1 Average daily demand

The maximum daily demand is calculated from what municipality perceived to be the daily water demand per capita, the quantity they use is in line with the recommendation in the literature. Then there are additional demands taken into account.

4.3.2 Distribution losses

The losses down the supply chain have been estimated by the municipality using water management computer software and their estimation was used in the calculations.

4.3.3 Population extrapolation

The Central Statistical Authority in Ethiopia have done population censuses and a part of estimating the water demand was to use these numbers to forecast the population in year, 2020 and 2030. This was done with the regression tool in Excel.

4.4 VULNERABILITY ASSESSMENT

The scope of the vulnerability assessment was hazards and hazardous events regarding water quantities per capita from the rainfall to the users in the surface source supply chain. The following steps: rainfall, catchment, reservoirs, distribution network and consumer demand is included in the assessment. The question the assessment tries to answer is what availability or demand parameters will be most significant in the change of water quantity now and for the projected scenarios of 2020 and 2030?

The assessment is developed from the WSP approach using module 2- 4 in the ‘Water Safety Plan Manual - Step-by-step risk management for drinking-water suppliers’ to assess the specific hazard of water scarcity (IWA & WHO, 2009).

First the water supply system was described by the flow chart with quantified sub flows seen in Figure 13.

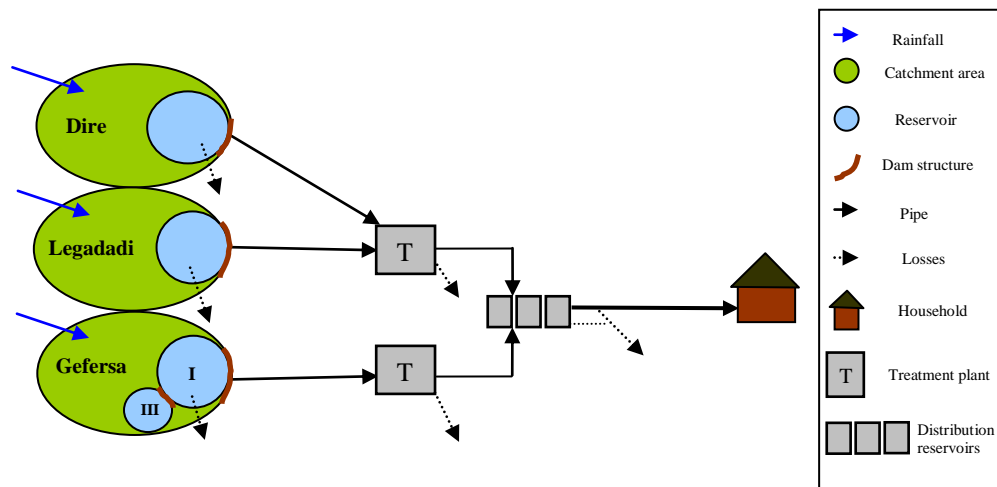

Figure 13. The flow chart graphics used for describing the water supply system. All the flows (arrows) were quantified.

Then the various hazardous events leading to the studied hazard were identified. A hazardous event is defined as something that can reduce the availability of water per capita in the supply chain, causing water scarcity and does not necessarily have to be events that already have occurred.

After that the hazardous events were assessed individually. This was done by dividing the hazardous events into three categories regarding likeliness (unlikely, possible and most likely) and three categories regarding severity (minor, major and catastrophic). These formed a risk matrix that gave each hazardous event a score (Figure 14). The

reason why risk matrix methods are used is because they can help to distinguish between significant and less significant risks in a less subjective matter (IWA & WHO, 2009).

Likelihood \ Severity	Minor	Major	Catastrophic
unlikely	1	2	3
Possible	2	4	6
Most likely	3	6	9

Figure 14. Risk matrix developed from Deere et al. (2001).

Finally the hazardous event will be ranked based on their risk score and the hazardous events that had risk score 4 or higher was seen as focus areas and those are further discussed in the discussion. The idea is that the ranking of hazardous events is useful when appropriate measures shall be suggested regarding water supply quantity from surface sources.

5 RESULTS

This section presents the results, it will mainly be presented in graphs and tables divided into four categories. First the result of the estimated present and future water balances will be presented, then present and future water demands, then the extreme event review findings and finally the vulnerability assessment.

5.1 PRESENT WATER BALANCE

Three reservoir water balances were made, one for Legadadi, one for Dire and one combined for Gefersa I and III. The idea was to make sure that the inflows match the outflows and this requires flow estimations which were retrieved from several sources. Catchment runoff, direct rainfall, evaporation, seepage and raw water intake to the treatment plants was estimated and the remaining difference between inflow and outflow in the water balance must then be water spillage.

The catchment runoff used was the average value of the available estimation that consultants before had made. In Table 2 all the figures used are presented. Future values were not taken from simulations or calculated but instead was the likely runoff change scenarios of 0%, 5% and 10% used.

Table 2. The result from the different catchment runoff estimation methods used and their calculated average annual runoff.

Method	Gefersa	Legadadi	Dire	unit	source
Catchment area	55.6	225.0	72.0	km ²	AAWSA,1993
Modelling (SCS)	-	-	33 900 000	m ³ /year	AAWSA,1995
Regionalization	23 400 000	67 500 000	43 600 000	m ³ /year	AAWSA,1995
Regionalization + Regression	29 400 000	72 000 000	47 500 000	m ³ /year	AAWSA,1993,1995
Gauged (only 1 year)	28 100 000	-	-	m ³ /year	AAWSA, 2002
Average	27 000 000	69 800 000	41 700 00	m ³ /year	

Evaporation was calculated from a simplified Penman equation, for further details of the calculations see Appendix A. The present average direct rainfall on the reservoirs was calculated using daily measured rainfall from the last 5 years available at the meteorological station in Bole. The modelled evaporation was compared with measured 5 year average evaporation. The modelled value was 105.3mm per month compared to the measured value of 117.7mm per month; this is a 12% difference. See Appendix B for the monthly data used. The future predicted temperature (effecting the evaporation) change is taken from the UNDP climate change country report of Ethiopia (UNDP, 2007). For future predicted rainfall levels was 0%, 5% and 10% used.

Seepage was calculated assuming that Dire dam bottom seepage rate can be used for all sites as described in the methodology section and no future change is assumed. One of the senior engineers stated that assuming that the geology under the reservoir locations is fairly similar and that it is an okay assumption to make. This assumptions leads to the seepage calculations of the reservoirs presented below in Table 3.

Table 3. The seepage for Legadadi and Gefersa was calculated from the known per area seepage of Dire.

Seepage calculation	Seepage ($m^3/year$)	Area (m^2)	Seepage per m^2 ($m^3/year$)/(m^2)
Dire	900 000	650 000	1.4
Legadadi	5 500 000	4 000 000	1.4 (assumed)
Gefersa I + III area	2 500 000	1 704 000	1.4(assumed)

The raw water intake was calculated by using the known supply rate from the treatment plants and the known water loss in the treatment process and no future change is estimated. The numbers are presented below in Table 4.

Table 4. A process loss factor of 6% was used to calculate the raw water intake to the treatment plant knowing the amount of treated water distributed.

	Legadadi	Dire	Gefersa	Unit
Treated water	126 800.00	38 200.00	30 000.00	m^3/day
Process loss factor	0.06	0.06	0.06	-
Raw water Supply	134 408.00	40 492.00	31 800.00	m^3/day
Raw water Supply	49 058 920.00	14 779 580.00	11 607 000.00	$m^3/year$

When these flows have been estimated the remaining inequality between inflow and outflow is assumed to be the spillage of excessive water during the rainy season. The average total water volume that flow through the three systems per year is for the scenarios with 0%, 5% and 10% change in rainfall/runoff presented in Table 5 according to the water balance equation (equation 1).

Table 5. The water balances for the different rainfall scenarios divided in inflows and outflows.

Change (%)	Total Flow ($10^6 * m^3/year$)	Inflow ($10^6 * m^3/year$)		Outflow ($10^6 * m^3/year$)			
		Q_{in}	P	Q_{sp}	I	Q_{se}	E
0	147	138	8	55	75	9	8
5	154	145	9	62	75	9	8
10	162	152	9	69	75	9	8

A more excessive water balance table is presented in Appendix C with all inflows and outflows. The estimated total outflow for the present situation (0% change) is presented as a pie chart in the Figure 15 to enable the reader to get an overview of what the water is used for.

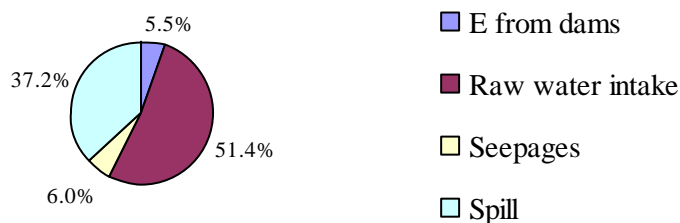

Figure 15. Estimated outflows for the present situation (0% change).

5.2 CHANGES IN SPILLAGE

The three scenarios for 2020 and the three for 2030 regarding perceived rainfall/ runoff change (0%, 5% and 10%) turned out very similar. This is due to the small impact

temperature (evaporation) change has on water volume reduction through reservoir surface evaporation. It was only 0.3‰ per decade. 2020 and 2030 are therefore presented together below in Figure 16-18 but all specific sub flows for all scenarios can be found in Appendix C.

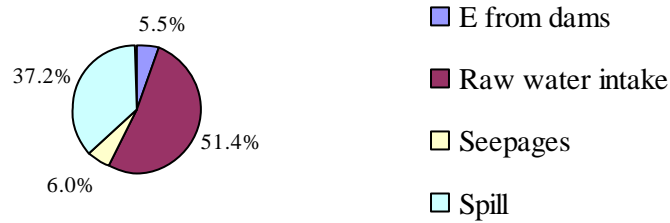

Figure 16. Estimated outflows for the 2020 and 2030 situation (0% change).

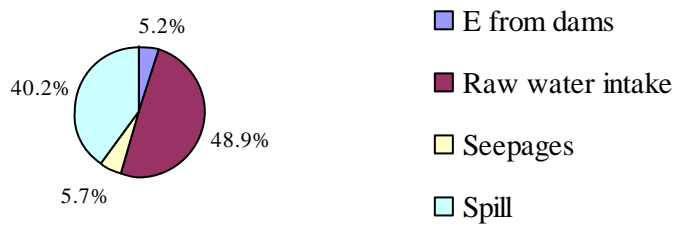

Figure 17. Estimated outflows for the 2020 and 2030 situation (5% change).

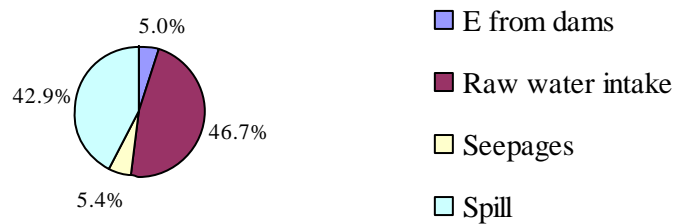

Figure 18. Estimated outflows for the 2020 and 2030 situation (10% change).

Using the spillage from the three rainfall scenarios seen above in the systems will gain approximately 0.6 percent available water margin (spillage) per percent increased rainfall/runoff change (comparing with present numbers). This linear correlation is presented graphically below in Figure 19.

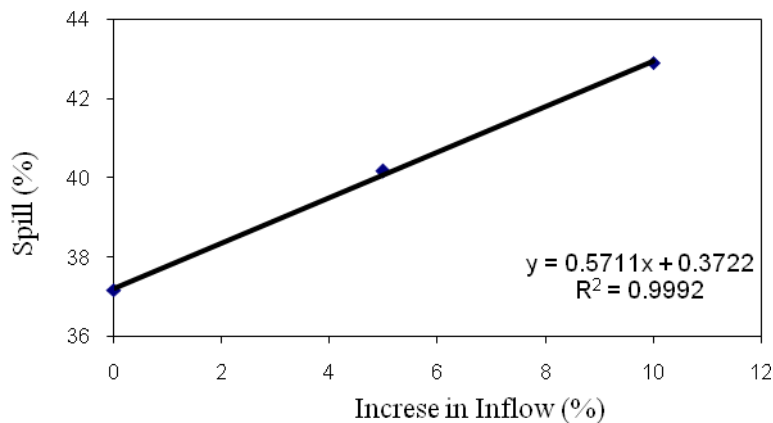

Figure 19. The linear correlation between percentage increase in inflow and percentage spillage.

5.3 WATER DEMAND

According to AAWSA (2011) about 195000 (65%) out of the 301000L of water provided to Addis Ababa is from the reservoirs. It is assumed that this percentage will be constant within the whole study time horizon. 110L per capita is the MDD used by the AAWSA and it is based on previously made consumer survey. That number is between the calculated MDD from the two literature recommendation that are mentioned in the review. The demand figures used for the calculation can be seen in Table 5 and 6 and the theory is presented in the literature review.

Table 5. The MDD figure is presented in bold, with 50L per capita per day as the ADD and other demands calculated as recommended.

Demands, sufficient amount (50L)	Unit	Source
Daily water demand (DWD)	50 L/capita/day	Gleick, 1996
Commercial and institutional water demand (CIWD) 50L	5 L/capita/day	MWR, 2002
Industrial water demand (IWD) 50L	15 L/capita/day	MWR, 2002
Added flow for daily peak factor 50L	7.5 L/capita/day	MWR, 2002
Maximum daily demand (MDD) if 50L	77.5 L/capita/day	Gleick, 1996

Table 6. The MDD figure is presented in bold, with 100L per capita per day as the ADD and other demands calculated as recommended.

Demands, optimal amount (100L)	Unit	Source
Daily water demand (DWD)	100 L/capita/day	Howard et al, 2003
Commercial and institutional water demand (CIWD) 100L	10 L/capita/day	MWR, 2002
Industrial water demand (IWD) 100L	30 L/capita/day	MWR, 2002
Added flow for daily peak factor 100L	15 L/capita/day	MWR, 2002
Maximum daily demand (MDD) if 100L	155 L/capita/day	Howard et al, 2003

The next thing needed to be calculated was the population size. The most recent census was in 2007 so the population for 2011, 2020 and 2030 was projected through exponential regression. The data that was used was the population of Addis Ababa from the 8 scattered years when there has been censuses seen in the graph below as blue dots. The predicted population growth curve and the population size of the studied years are presented in Figure 20 and Table 7.

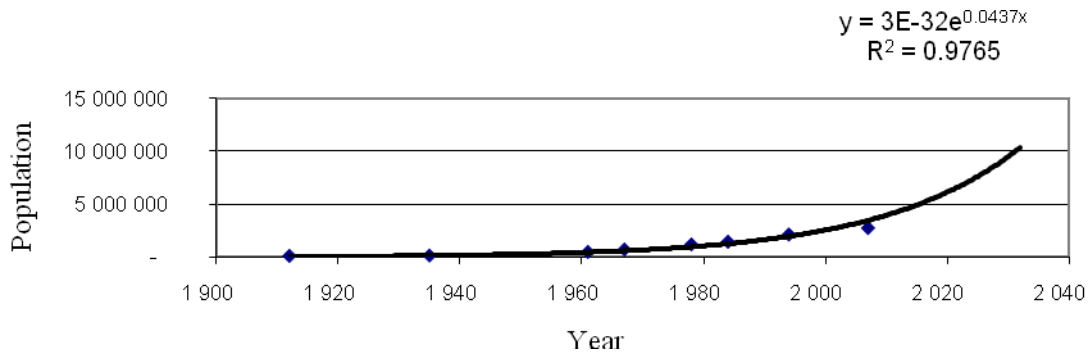

Figure 20. Population growth curve made from population data with exponential regression.

Table 7. This is the population size of the studied years of 2011, 2020 and 2030 according to the used population growth curve.

Population projection		
Year	Population	Unit
2011	4 397 000	Capita
2020	6 516 000	Capita
2030	10 088 000	Capita

To know the supply demand for Addis Ababa the physical water losses in the system must be taken in account. They lose approximately 20% of the water due to pipe leakages and intermediate reservoir leakages. In Table 8 the treated water flows from the two treatment plants are presented and the total water supply including system loss is the figure presented in bold.

Table 8. The total supplied water to Addis Ababa from surface sources.

Supply water balance	Legedadi treatment plant	Gefersa treatment plant	Total from treatment plants	Unit	Source
Treated water/day	165 000	30 000	195 000	m ³ /day	AAWSA, 2011
Physical loss factor	0.20	0.20	0.20	%	AAWSA, 2011
Supplied water	48 200 000	8 800 000	56 900 000	m ³ /year	

The MDD of 110 litres, the population sizes, the water supply from surface sources including system losses and climate change impact was then used to calculate the present and future coverage in percent presented in Table 9. Assuming that no new water sources were built and that maintenance and degradation is even, meaning that losses are at the same rate. The present water coverage situation is that 50% of the demand is met. The future trend regarding water coverage in Addis Ababa is clearly declining assuming no new sources are built.

Table 9. Population and demand data is used to calculate the future coverage rate without taking future development into account.

Water Demand	Present	2020	2030	Unit
Demand	110	110	110	L/capita/day
Pop. of Addis Ababa	4 300 000	6 500 000	10 000 000	Capita
From surface sources (65%)	2 800 000	4 200 000	6 500 000	Capita
Total demand	114 300 000	169 500 000	262 400 000	m ³ /year

Total supply	56 900 000	56 900 000	56 900 000	m ³ /year
Coverage	50%	34%	22%	

5.4 RAINFALL EXTREMES

The extreme event section will only consider rainfall events. The likely scenario for Addis Ababa is increased rainfall intensity and more extreme weather such as rainstorms and high yearly variation. The figures presented in the result part are all based on previous rainfall data and do not take climate change in account.

Even though the future probably will give more rain a more variable climate could result in more frequent dry year extremes. Table 10 is based on data found in one of the consultancy reports, presenting the rainfall amount and average return period for these yearly amounts (AAWSA, 1993).

Table 10. Rainfall amounts and average return periods for dry years.

Dry year extreme events	
Return period (years)	Annual rainfall (mm)
2	1210
5	1040
10	980
50	910
100	900

The effect of a dry year extreme, with a return period of 100 years, on the availability of reservoir water for treatment and supply is shown below in Figure 21. The water balance during such a year with annual rainfall of 900 mm (a reduction of 27% compared with the annual present average) will have an estimated spillage of 14%.

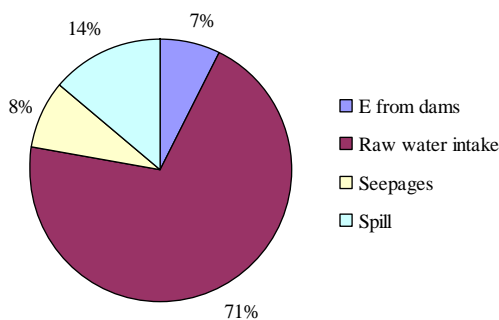

Figure 21. The effect on the availability of reservoir water for treatment and supply for the 100 year return periods of dry year shown as percentages of the outflows in the reservoirs in total.

Another interesting aspect to consider is intensity, the rainfall amount of isolated rainstorm events depending on their duration. In Table 11 the duration and amount of the average yearly maximum rainfall of these specific events are presented. The data has been found in consultancy reports (AAWSA, 1993 and AAWSA, 1995a).

Table 11. The average yearly maximum amount of rainfalls recorded for different durations (AAWSA, 1993 and AAWSA, 1995a),

Maximum recorded rainfall

Duration	Rainfall amount (mm)
1 hour	34.5
24 hours	52.2
48 hours	71.2
72 hours	82.6

High intensity rainfall can cause problem but the dams are built to cope with such flows observed and more. Legadadi and Dire are designed for ‘Probable Maximum Floods’ of 1800 m³/s respectively 880 m³/s, meaning the spillways can cope with such amount without a significant negative impact on the infrastructure (AAWSA, 1993). Gefersa I on the other hand is not designed with ‘Probable Maximum Floods’ and does not have spillways, the water just flows over the crest. The largest measured flow in Gefersa I was in august 1989 when they had an estimated inflow to the dam of 180 m³/s, a water level of 35cm over the crest and spillage of 50 m³/s. Table 12 presents the flow created by maximum recorded rainstorms. None of these flows is higher than the design flows.

Flow created by average yearly maximum rainfall				
Duration	Legadadi Flow	Dire Flow	Gefersa Flow	Unit
1 hour	2 156	690	533	m ³ /s
24 hours	136	44	34	m ³ /s
48 hours	93	30	23	m ³ /s
72 hours	72	23	18	m ³ /s

Table 12. The flow potentially created by maximum rainfall for specific durations.

Further, the average annual rainfall for the last century shows that there is variability in rainfall. The maximum and minimum variability from the 20 last year’s average are 27% and -25%. The last 20 years variability is illustrated in Table 13. The data is there divided into five categories, 5% and 10% higher and lower than the average rainfall as well as the percentage of the data that lay 5% or closer to the annual average.

Table 13. The table presents the part of the annual rainfalls that is 5% and 10% higher or lower than the average rainfall from 1990-2010 rainfall data during that period.

SRA	Percentage of years
>10% anomalies wet year	25%
>5% anomalies wet year	15%
no large anomalie	20%
<5% anamolie dry year	20%
<10% anamolie dry year	25%

5.5 VULNERABILITY ASSESSMENT

The first task in the step by step water quantity reduction risk assessment was to describe the water supply system with a flow chart with quantified sub flows. Such flow chart is presented below in Figure 23.

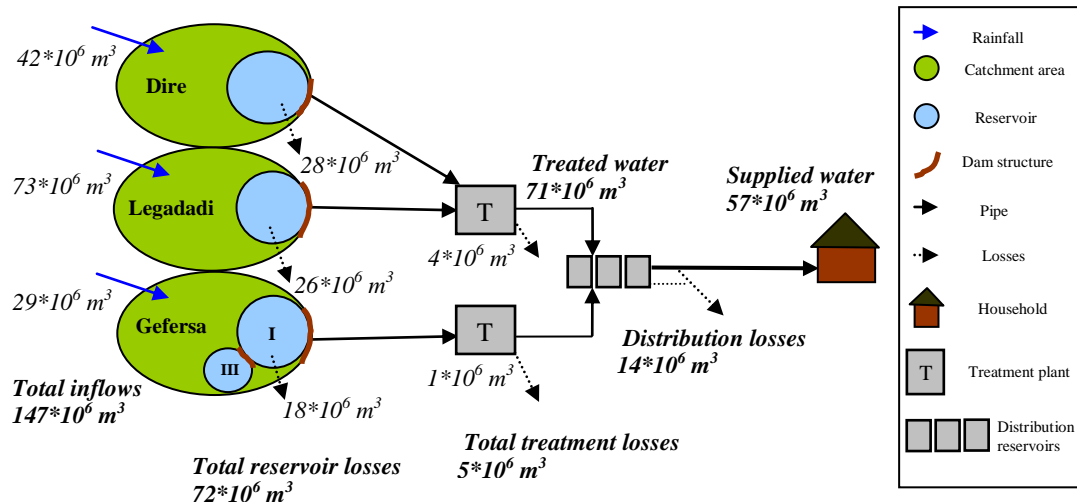

Figure 23. Flow chart used for describing annual flows in the studied water supply system.

A holistic and as well covering as possible list of hazardous events in accordance with the definition described in the methodology was made. Table 14 is the list of hazardous events with some comments on each.

Table 14. List of hazardous events and comments.

Hazardous event	Comments
Increase in average temperature	This will most likely occur but the water quantity lost, even with the most extreme climate change scenario, leads to small (0.3‰ reduction per decade) contribution due to evaporation.
Decrease in average rainfall	This is a very unlikely scenario, neither the observed data or the climate models suggest that. (McSweeney et al., 2007; Conway et al., 2004 and WHO & DIFID, 2010)
Increase in extreme droughts event	The literature (WHO & DIFID, 2010; Few et al. 2004 and Christensen et al. 2007) suggests that all extreme events will increase but the margin to not fill up the reservoirs due to dry year is probably small even a drought with the return period of 100 year is not enough (figure 21). This result was confirmed with senior engineers at AAWSA.
Overexploited land	There has been deforestation and heavier land use the last decades leading to effects on the hydrology in the catchments such as lower water buffering capacity and more intermittent inflows to the dams according to staff at AAWSA. The severity is hard to estimate but the literature claims such change can be significant. (Cuo et al. 2009 and Herron et al. 2002).

Dam losses increase	With time, the losses through the structure will increase but the volumes are small. A more severe issue would be increased algae growth, with risk of reduced usable volumes but the quantities is probably not major (AAWSA, 1982).
Dam failure	The dams are designed to cope with return periods over 1000 years. So the risk of total failure is very small. (AAWSA, 2002)
Treatment losses increase	The present losses in the treatment plant will likely decrease not increase due to better technology and a planned sludge water reuse scheme according to AAWSA staff.
Treatment failure	If one of the treatment plants would fail other water sources could cover for it for a short period of time to cover basic needs but if both would fail for a longer period the consequences would be sever. But this is a very unlikely scenario.
Distribution losses increase	The pipe system is old (up to 40 years) and the economical means are scarce so the likeliness of loss increase is large.
Distribution failure	Scenarios such as transmission pipe failure or ingress of biological or chemical contamination to a lever that the water is unusable is very unlikely according to AAWSA staff but if this would happen the consequences would be catastrophic.
Increased per capita water demand	This is also a very likely scenario when the annual economic growth above 7%. Higher demand leads to higher risk of water stress (Alcamo <i>et al.</i> , 2007).
Increases in population	This is a very likely scenario; the projections made in this study indicate an annual population growth of approximately 4.4% (figure 20).

When the hazardous events were identified each of these hazardous events were assessed and scored using the Deere et al. (2001) risk matrix approach presented in the methodology. In Table 15 the assessed and scored hazardous events are presented.

Table 15. List of the assessment and risk score of the identified hazardous events.

<i>Hazardous event</i>	<i>Severity</i>	<i>Likeliness</i>	<i>Score</i>
Increase in average temperature	Minor	Most likely	3
Decrease in average rainfall	Major	Unlikely	2
Increase in extreme drought events	Minor	Most likely	3
Overexploited land	Major	Possible	4
Dam losses increase	Minor	Possible	2
Dam failure	Catastrophic	Unlikely	3
Treatment losses increase	Minor	Unlikely	1
Treatment failure	Catastrophic	Unlikely	3
Distribution losses increase	Major	Possible	4
Distribution failure	Catastrophic	Unlikely	3
Increased per capita water demand	Major	Most likely	6
Increases in population	Major	Most likely	6

At last the hazardous events were ranked based on their risk score (Table 16).

Table 16. Ranking list of the hazardous events identified. The colours in the table are based on the colours found in the risk matrix example in the methodology.

Ranking of hazardous events
Increased per capita water demand
Increases in population
Overexploited land
Distribution losses increase
Increase in average temperature
Distribution failure
Increase in extreme droughts event
Dam failure
Treatment failure
Decrease in average rainfall
Dam losses increase
Treatment losses increase

6 DISCUSSION

6.1 VULNERABILITIES FOR THE SURFACE SUPPLY

The vulnerability assessment of the supply from surface sources resulted in Table 16, a ranked list of hazardous events, each given a risk score. Following four main vulnerabilities were identified by having the highest risk score (4 or more). Increases in population, increased per capita water demand, overexploited land and distribution losses increase. The first two are both linked to total water demand and below is a discussion regarding the water demand of Addis Ababa. Overexploited land will impact hydrology but the cause to overexploitation is linked to socio-economical factors such as over population and poverty. Further discussion can be found in the overexploited land section later. Distribution losses increase is linked to poverty, causing lack of maintenance and replacement of aged pipes and will also be further discussion in the distribution loss section.

6.2 WATER DEMAND

As in many rapidly developing countries the combination of population and economical growth will put constraints on meeting public commodity demands. This is the case for Addis Ababa as well. The quantitative analysis did not take economic growth into account, it would only add on to the already clear trend that the water demand of Addis Ababa is the biggest factor regarding present and future water stress. With the perceived average demand per capita of 110L (AAWSA, 2011) the projected annual population growth of 4.37%, found in Figure 20, will by 2020 result in supply coverage of 34% of the total population and by 2030 it has reduced to 22% of the total population (Table 9). This result shows the risk of a severe reduction in water availability per capita in Addis Ababa. The findings are in line with the literature claiming that water scarcity can be a reality in a foreseeable future in Addis Ababa (Mintz et al., 2001; IWA, 2010 and UNECA, 1999). Still there are variables that could change the population trend such as family planning or a new famine. The last census does show a slightly lower than the trend line which could be an indication of a flattening population growth curve.

There are contexts where climate related factors such as demographic and socioeconomic issues are the main contributors to water stress (Alcamo *et al.*, 2007). On the other hand migration to cities and various types of poverties can be linked in complex ways with climate change, therefore population growth should not be ruled out too quickly as climate change induced stress (Clifford, 2009).

According to AASWA (2011) 73% of the city demand is covered, the estimations made in this study however, indicate a present coverage rate of 50% (Table 9). This discrepancy could be explained by the different methods used. In this study distribution losses and peak hour factor were taken into account as well as slightly higher population numbers.

6.3 WATER AVAILABILITY

The overall water balance result indicated that there is plenty of available water for Addis Ababa on an annual basis but due to uneven temporal distribution, the dam capacities are not sufficient. According to Figure 15, 37% of the available annual water volume is at present non-utilised and spilled downstream to the Awash river. If the most likely future scenario of increasing rainfall and subsequently increased runoff will occur, the percentage of non-utilised water in the reservoirs will increase by 0.6% per percent rainfall/runoff increase (Figure 19). Regarding the hydrology of the reservoirs

there is no other parameters that will affect the water availability more than rainfall change. The temperature effect through evaporation is small; it will be only 0.3‰ per decade. Neither rainfall nor temperature affects water availability in a large extent compared to the demand change. One aspect to take into account is the longer time span needed to see the effect from present carbon emissions. The time horizons used in this study are not sufficient to see heavier impact from average climate change (Praskiewicz, 2009). If we look at extreme weather events, which probably will increase, a drought year with return period of 100 years would result in a reduction of the spillage of 27% compared with the annual present average. The spillage or the availability margin/spillage such a year would still be 14% according to Figure 21. This shows that even such year there is a margin in available water. One of the engineers that had worked with the dams for many decades at AAWSA claimed that he had almost no experience with water not reaching the upper limit of the dams. Perhaps 14% is needed as ecological flow downstream and should not be seen as unutilised water and thus the extreme event of droughts should not be ruled out as a potential risk.

Furthermore, capacity could be reduced due to algae growth, induced by temperature increase, and there could be some additional seepage due to aging and capacity reduction due to sedimentation. The water provision to the reservoirs is not insufficient but the holding capacity is. There is, according to one of the engineers at AAWSA, plans on increasing the crest of Dire dam. This would require an increase in the volume through the treatment plant which would be a rather expensive project. Another coming project that will help the water provider to utilise the stored water better is the plan of initiating a sludge water reuse scheme.

6.4 OVEREXPLOITED LAND

Consultancy reports, engineers at AAWSA, and the literature study all mentioned the land exploitation as a factor that affect the runoff characteristic. An engineer who has been working with the dams for many decades said that he has seen a change in runoff; many streams that previously were flowing all year around are now intermittent. The consequence of the change in runoff characteristics is a shorter period when the dam is filled up. In the literature land cover change is said to continue throughout this century and continue to be together with climate change the two major factors to global change (Olson *et al.*, 2008).

A study by Cuo *et al.* (2009) on land-cover change and climate change for the next century showed that land cover issues are especially important in highland areas. There are even indications that land cover change probably will affect water resources more significantly than climate change (Herron *et al.* 2002). This is in line with the vulnerability ranking in this study, and despite not quantifying the sensitivity of changes in runoff related to land use nor assessing the land use in the catchment, there are indications that it is a significant factor.

6.5 DISTRIBUTION LOSSES

The physical water loss in the Addis Ababa water distribution system is approximately 20%. This water loss is according to one of the engineers mainly due to aging pipes. There is no major pipe replacement project planned and subsequently this distribution loss percentage will increase in the near future. The pipe system is not likely to be extended in the same pace as the population of Addis Ababa will increase. Thus if AAWSA is going to cope with the growing water demand they need to increase the

pressure in the pipes. This was confirmed by one of the AAWSA engineers, who added that the higher pressure in the distribution pipes will increase the loss significantly. And he called for a broad and holistic approach regarding the water supply. Perhaps a WSP covering all aspects of the water supply could be what AAWSA needs.

6.6 FUTURE DEVELOPMENT

In the consultancy reports the most frequent suggestion for the future is that new larger dams should be built, and the best locations are north of the Entoto ridge, meaning that the water then would be taken from the Abbay (Blue Nile) river basin and that the water should be transmitted in a tunnel through the Entoto ridge. This was mentioned by the engineers as well, but there are at present no funds for such massive project.

Furthermore, reducing the water volume of the Nile is politically an extremely sensitive issue. Therefore this 'next step' is postponed to an unknown future.

As an interim solution, or emergency solution as it is called in some of the consultancy reports, AAWSA has drilled wells south of Addis Ababa, coping with the growing demand by adding ground water to the supply scheme. This approach can and will continue during the next few years and will most likely lead to a better coverage percent. According to AAWSA (2011) the new wells built this year will result in a coverage increase from the 73% to 98% (this is equivalent to 67% if using distribution losses and peak hour factor). With the good surface water resources uphill from Addis Ababa the push towards groundwater will likely be a temporary addition in the race against growing demand. Surface sources are probably a more sustainable solution due to the energy cost of pumping water uphill from the low land well field.

6.7 LIMITATIONS

There are a number of aspects that could be improved regarding the way this study was conducted. Perhaps could the now existing lack of validation be reduced if the inflows had been gauged during a long time and hydrological models of each of the three catchments would have been set up. This was not feasible due to time and human resource limitations. Instead the study had to use the result from consultancy reports and estimated values.

Another aspect is that future hydrological projection results can vary a lot even if the simulation is done well. There is no guarantee, even with very robust data, of precise flow values. A study by Frei *et al.* (2002), cited in Praskievicz *et al.* (2009) that was conducted in the Catskill Mountains, an area which supply New York City with drinking water, showed potential changes in the supply due to climate change. But the result of the available water supply in the future (2080) varied a lot between the different models used. The range was from a decrease of 30% to an increase of 10%, due to how the precipitation was projected.

The water balance model is built on an assumption that the water not leaving the system through evaporation, water distribution, and seepage, is spillage and that spillage is the same as the non-utilised water. This simplification does not take management and temporal change in account which could vary or change in the future.

One question that should be asked is if the data has been collected well in the first place. Ethiopia suffered by a civil war and very limited resources during time periods

overlapping with some of the meteorological data. This might have lowered the quality of the measurements taken during those times and be a source of bias.

Finally, in an assessment where future projection of the climate, urban water issues, and water demand are taken into account there must be clear limitation of what is assessed. These limits were hard to set up and it is possible that something essential was missed. In such a complex and changing field as this is, it is hard to come to anything but quite general conclusions because the assessment is partly based on estimations rather than robust data.

To add credibility to this method, which is in large based on estimations, there was a need of using not only the calculated values but additional data. This was done by using complementary sources such as reviewing others experiences described in the literature and consultancy documents as well as getting information from key informants such as two senior engineers at AAWSA that know the system very well.

7 RECOMMENDATIONS

The following recommendations can be made based on the study. There is a need to focus on understanding and finding measures for the risks with the highest risk score (population growth, increased per capita demand, overexploited land and distribution losses increase). The recommendation regarding water distribution is to find means to be able to use the larger water bodies north of the Entoto ridge. Risk assessment is needed for the whole system, covering more aspects than done in this study, and AAWSA should investigate the possibilities of implementing a WSP for the entire water supply system.

8 CONCLUSIONS

The supplied water quantity per capita from surface sources in Addis Ababa is likely to reduce over the next couple of decades. This is due to various vulnerabilities related to the water supply situation. Twelve vulnerabilities, both climate and socio-economic related, were identified and ranked with a risk matrix. The four following vulnerabilities had the highest risk score; population growth, increased per capita water demand, overexploited land and distribution losses increase. There is an increase in population by 4.4% annually, and the increased per capita water demand is linked to the more than 7% annual increase of economic growth. Combining these two factors are leading to a growing water demand in Addis Ababa, and if not substantially more water sources are added this can lead to economic water scarcity. By 2020 the water demand coverage could be 34% of the total population and by 2030 it could be reduced to 22% compared to the present 50% coverage.

Senior staff at the AAWSA identifies the vulnerability overexploited land as one of the main issues due to the impact it has on catchment hydrology. Distribution losses increase is linked to the lack of economic means, causing lack of maintenance and replacement of aged pipes. At present 20% of the treated water is lost in the distribution network and according to engineers at AAWSA it is likely to increase during the coming decades.

Climate change will have an effect of climate variability leading to more frequent dry year extremes that could put stress on the water distribution. For the surface source water supply in Addis Ababa the effect of rainfall variability will not be the main concern. Even a dry event with a return period of 100 years, leading to an annual rainfall of 900 mm, causes a reduction of 27% compared with the annual present average. The spillage or the availability margin would in such a year still be 14%.

To secure water distribution in the long run AAWSA should use the larger water bodies north of the Entoto ridge as surface sources and also work on getting further understanding and finding appropriate measures for the risks with higher risk score. For the future risk assessment is needed for the whole system, and should cover more aspects than done in this study, and AAWSA should consider implementing a WSP for the entire water supply system.

9 REFERENCES

- AAWSA (2011), *AAWSA: A brief summary*, accessible as hardcopy in AAWSA Library, unpublished document.
- AAWSA (2002), *Gafarsa and Keranyo water supply - Rehabilitation of dams and water treatment plant*, consultancy report, accessible as hardcopy in AAWSA Library.
- AAWSA (1995a), *Dire Dam project – Addis Ababa emergency water supply - detailed design report*, consultancy report, accessible as hardcopy in AAWSA Library.
- AAWSA (1995b), *Hydrology of Gerbi*, consultancy report, accessible as hardcopy in AAWSA Library.
- AAWSA (1982), *Production facilities and Lagadadi transmission line - volume II*, consultancy report, accessible as hardcopy in AAWSA Library.
- Alcamo, J., Flörke, M. and Märker, M. (2007), Future long-term changes in global water resources driven by socio-economic and climatic changes, *Hydrological Sciences vol. 52*, p. 247–75, Informaworld.com, (online publication).
- Ayenew, T., Demlie, M. and Wohnlich, S. (2008), Application of Numerical Modeling for Groundwater Flow System Analysis in the Akaki Catchment, Central Ethiopia *Mathematical Geoscience*, vol. 40, p. 887–906, International Association for Mathematical Geology (online publication).
- Bartram, J., Corrales, L., Davison, A., Deere, D., Drury, D., Gordon, B., Howard, G., Rinehold, A. and Stevens, M. (2009) *Water safety plan manual: step-by-step risk management for drinking-water suppliers*, WHO Press, Geneva.
- Britannica (2011), *Britannica Online Encyclopaedia*, available at: <http://www.britannica.com/EBchecked/topic/499101/reservoir?anchor=ref264677>, accessed 31-06-2011.
- Christensen, J. H., Hewitson, B., Busuioc, A., Chen, A., Gao, X., Held, I., Jones, R., Kolli, R. K., Kwon, W-T., Laprise, R., Magaña, Rueda, V., Mearns, L., Menéndez, C. G., Räisänen, J., Rinke, A., Sarr, A. and Whetton, P. (2007), *Regional Climate Projections. In: Climate Change 2007: The Physical Science Basis. Contribution of Working Group I to the Fourth Assessment Report of the IPCC*, Solomon, S., Qin, D., Manning, M., Chen, Z., Marquis, M., Averyt, K. B., Tignor, M. and Miller, H. L. (editors), Cambridge University Press, Cambridge, United Kingdom.
- CIA World fact book (2011), available at: <https://www.cia.gov/library/publications/the-world-factbook/geos/et.html>, accessed 31-06-2011.
- Clifford, N.J. (2009), Globalization: a Physical Geography perspective, *Progress in Physical Geography*, vol. 33, p. 5–16. Sage publications, Thousand Oaks, USA
- Conway, D., Mould, C. and Bewket, W. (2004), Over one century of rainfall and temperature observations in Addis Ababa, Ethiopia, *International Journal of Climatology*, vol. 24, p. 77-91, Wiley InterScience (online publication).

Crampton, J. (2005), *Unpublished Internal WaterAid paper*, available at: http://www.wateraid.org/documents/plugin_documents/water_quality_for_addis_briefing_note.pdf, accessed 31-06-2011.

CSA (2007), *Census Summary - Population size and spatial distribution*, available at: www.csa.gov.et/index.php?option=com_rubberdoc&view=category&id=62&Itemid=70, accessed 31-06-2011.

Cuo, L., Lettenmaier, D.P., Alberti, M. and Richey, J.E. (2009) Effects of a century of land cover and climate change on the hydrology of the Puget Sound basin. *Hydrological Processes*, vol. 23, p.907–33, Wiley InterScience (online publication).

Deere, D., Stevens, M., Davison, A., Helm, G., Dufour, A. (2001), *Management Strategies*, in: *Water quality: guidelines, standards and health – assessment of risk and risk management for water-related infectious disease*, Fewtrell, L., and Bartram, J. (Editors), London, IWA Publishing.

Drinking water inspectorate (2005), *A Brief Guide to Drinking Water Safety Plans*, available at: <http://dwi.defra.gov.uk/stakeholders/guidance-and-codes-of-practice/Water%20Safety%20Plans.pdf>, accessed 31-06-2011.

Ethiopian Embassy (2011), *Quick Facts about Ethiopia*, available at: http://www.ethemb.se/ee_ethiopia.html, accessed 31-06-2011.

Few, R., Ahern, M., Matthies, F. and Kovats, S. (2004), Floods, health and climate change: a strategic review, *Working Paper No. 63*, Tyndall Centre for Climate Change Research, Norwich, United Kingdom.

Gadaa.com (2011), *River basins in Oromia*, available at: <http://www.gadaa.com/RiverBasinOromiaEthiopia.JPG>, accessed 31-06-2011.

Gleick, P. H., Cooley, H., Morikawa, M. (2009), *The World's Water 2008-2009: The Biennial Report on Freshwater Resources*, Island Press, Washington DC.

Gleick, P. H. (1996), Basic water requirements for human activities: meeting basic needs, *Water International*, no. 21, p. 83-92.

Graham, N.E. and Georgakakos, K. P. (2006), Simulating the value of El Niño forecasts for the Panama Canal, *Advances in Water Resources*, vol. 29, p. 1665–1677, Elsevier, New York.

Hayes, M.J. (2011), *What is drought?*, available at: <http://www.drought.unl.edu/whatis/indices.htm#pdsi>, accessed 31-06-2011.

Herron, N., Davis, R. and Jones, R. (2002) The effects of large-scale afforestation and climate change on water allocation on the Macquarie River catchment, NSW, Australia. *Journal of Environmental Management*, Vol. 65, p. 369–81, Elsevier, New York.

Howard, G. and Bartram, J. (2010), *Vision 2030 - The resilience of water supply and sanitation in the face of climate change - Technical report*, available at: http://www.who.int/water_sanitation_health/publications/9789241598422_cdrom/en/index.html, accessed 31-06-2011.

Howard, G. and Bartram, J. (2003), *Domestic Water Quantity, Service, Level and Health*, WHO Press, Geneva, Switzerland.

International Water Management Institute (2007a), *2006-2007 Annual Report*, available at: http://www.iwmi.cgiar.org/About_IWMI/Strategic_Documents/Annual_Reports/2006_2007/theme1.html, accessed 31-06-2011.

International Water Management Institute (2007b). *Water for food, water for life: a comprehensive assessment of water management in agriculture*, Earthscan and Colombo, London.

IPPC (2011), *What is a GCM?*, available at: http://www.ipcc-data.org/ddc_gcm_guide.html, accessed 31-06-2011.

IPCC (2007), Working Group II definition, available at: http://www.ipcc.ch/publications_and_data/ar4/syr/en/spms1.html, accessed 31-06-2011.

IWA (2010), *Addis Ababa: Sanitation Status*, available at: <http://www.iwawaterwiki.org/xwiki/bin/view/Articles/3%29+ADDIS+ABABA+%28Ethiopia%29+3>, accessed 31-06-2011.

IWA & WHO (2009), *Water Safety Plan Manual Step-by-step risk management for drinking-water suppliers*, WHO Press, Geneva, Switzerland.

Kundzewicz, Z.W., Mata, L.J., Arnell, N.W., Döll, P., Kabat, P., Jiménez, B., Miller, K.A., Oki, T., Sen, Z. and Shiklomanov, I.A. (2007), Freshwater resources and their management, in: Parry, M.L., Canziani, O.F., Palutikof, J.P., van der Linden, P.J. and Hanson, C.E. (editors), *Climate Change 2007: impacts, adaptation and vulnerability, Contribution of Working Group II to the Fourth Assessment Report of the Intergovernmental Panel on Climate Change*, p. 173–210, Cambridge University Press, Cambridge, UK.

Linacre, E. T. (1993), Data-sparse estimation of lake evaporation using a simplified Penman equation, *Agricultural and Forest Meteorology*, vol. 64, p. 237-256, Elsevier, New York.

McSweeney, C., New, M., and Lizcano, G. (2007), *UNDP Climate Change Country Profiles Ethiopia*, available at: <http://country-profiles.geog.ox.ac.uk>, accessed 31-06-2011.

Ministry of Water Resources (MWR) (2002), *Water Sector Development Program, Main report Volume, Unpublished municipal document*, available at: <http://www.mowr.gov.et/attachmentfiles/Downloads/Water%20Sector%20Development%20Program%20Vol.2.doc>, accessed 31-06-2011.

Muller, M. (2007), Adapting to climate change: water management for urban resilience. *Environment and Urbanization*, vol. 19, p. 99–113. Sage publications, Thousand Oaks, USA.

Nishat, A., Reazuddin, M., Amin, R. and Khan, A. R. (2000), *1998 flood: impact on the environment of Dhaka city*, Department of Environment and IUCN. Dhaka, Bangladesh.

O'Hara, J. K. and Georgakakos, K. P. (2008), Quantifying the Urban Water Supply Impacts of Climate Change, *Water Resource Management*, vol. 22, p.1477–1497, Springer publishing, New York.

Olson, J.M., Alagarswamy, G., Andresen, J.A., Campbell, D.J., Davis, A.Y., Ge, J.J., Huebner, M., Lofgren, B.M., Lusch, D.P., Moore, N.J., Pijanowski, B.C., Qi, J.G., Thornton, P.K., Torbick, N.M. and Wang, J. (2008), Integrating diverse methods to understand climate–land interactions in East Africa. *Geoforum*, Vol. 39, no. 2, p. 898–911, Elsevier, New York.

Packard Foundation (2007), *Improving Lives and Slowing Population Growth: Six Years of International Grant making in Reproductive Health*, available at: <http://www.brothertonstrategies.com/docs/Packard.pdf>, accessed 31-06-2011.

Persson, K. M. (2009), “Tap, tank or bottle? - Aspects of drinking water consumption”, in: Förare, J. (editor), *Drinking water - Sources, Sanitation and Safeguarding*, Swedish Research Council Formas, Stockholm, p. 113-133.

Praskievicz, S. and Chang, H. (2009), A review of hydrological modelling of basin-scale climate change and urban development impacts, *Progress in Physical Geography*, vol. 33, no. 5, p. 650–671, Sage publications, Thousand Oaks, USA.

Sime, I. (1998), Addis Ababa water supply stage III-A project, *Ethiopian Association of Civil Engineers Bulletin*, vol. 1, no. 1, Ethiopian Association of Civil Engineers, Addis Ababa

UN Ethiopia (2011), *About Ethiopia*, available at: http://www.unethiopia.org/About_Ethiopia.aspx, accessed 31-06-2011.

UN-Habitat (2008), *Case study: Dhaka's extreme vulnerability to climate change. State of the world's cities 2008/2009*, available at: http://www.preventionweb.net/files/4292_Dhaka20extreme1.pdf, accessed 31-06-2011.

UNDP (2007), *MDG monitor: tracking the Millennium Development Goals*, available at: <http://www.mdgmonitor.org/goal7.cfm>, accessed 31-06-2011.

UNECA (1999), *Global environmental outlook 2000*, Earthscan, London.

UNEP (2000), *Climate Change and Dams: An Analysis of the Linkages Between the UNFCCC Legal Regime and Dams*, available at: www.dams.org/docs/kbase/contrib/env253.pdf, Accessed 31-06-2011.

UNEP/UNESCO/UN-HABITAT/ECA (2003), *Groundwater vulnerability mapping of the Addis Ababa water supply aquifers, Ethiopia*, available at: <http://www.unep.org/dewa/water/groundwater/English/GWhmEng/CountryProfiles/Ethiopia/AddisAbaba-Report.pdf>, accessed 31-06-2011.

United Nations Framework Convention on Climate Change (UNFCCC) (2007), *Climate change: Impact, vulnerabilities and adaptation in developing countries*, available at: unfccc.int/resource/docs/publications/impacts.pdf, accessed 31-06-2011.

Van Rooijen, D. and Taddesse, G. (2009), *Water, sanitation and hygiene: Sustainable development and multisectoral approaches - Urban sanitation and wastewater treatment in Addis Ababa in the Awash Basin, Ethiopia*, 34th WEDC International Conference, Addis Ababa, Ethiopia, available at: http://wedc.lboro.ac.uk/resources/conference/34/Van_Rooijen_D_-_95.pdf, accessed 31-06-2011.

Viner, D. (2002), *conceptual diagram of HadCM2*, available at: <http://www.ceaa-acee.gc.ca/default.asp?lang=En&n=9699932C-1&offset=16&toc=show>, accessed 31-06-2011.

WaterAid (2011), *Ethiopia country profile*, available at: www.wateraid.org/uk/what_we_do/where_we_work/ethiopia/, accessed 31-06-2011.

WHO (2009), *Gender, climate change and health*, WHO Press, Geneva, Switzerland.

WHO (2008), *Guidelines for drinking-water quality (Third edition)*, WHO Press, Geneva, Switzerland.

WHO (2003), *Domestic Water Quantity, Service Level and Health*, WHO Press, Geneva, Switzerland.

WHO & DIFID (2010), *Vision 2030 - Technology projection study*, available at: http://www.who.int/water_sanitation_health/publications/9789241598422_cdrom/en/index.html, accessed 31-06-2011.

WHO & UNICEF (2010), WHO/UNICEF (2010), *Progress on sanitation and drinking-water 2010 update*, WHO Press, Geneva, Switzerland.

Wilby, R.L., Charles, S.P., Zorita, E., Timbal, B., Wettot, P. and Mearns, L.O. (2004), *Guidelines for Use of Climate Scenarios Developed from Statistical Downscaling Methods*, available at: www.ipcc-data.org/guidelines/dgm_no2_v1_09_2004.pdf, accessed 31-06-2011.

APPENDIXES

APPENDIX A. The simplified Penman equation evaporation calculation.

Equation 3: $E_o = (0.015 + 0.00042T + 10^{-6}h) (0.8R_s - 40 + 2.5Fu(T-T_d))$

Equation 4: $T = (0.6T_{max} + 0.4T_{min})$

Equation 5: $T_d = bG / (a - G)$ where $G = (aT / (b + T) + \ln(RH/100))$

Data values		Units
T	18.11	°C
h(Legadadi)	2 500.00	m
h(Dire)	2 500.00	m
h(Gefersa)	2 500.00	m
Rs	5 260.00	W/m ²
F(Legadadi)	0.78	m
F(Dire)	0.78	m
F(Gefersa)	0.77	m
u	0.50	m/s
Td(Legadadi)	7.22	°C
Td(Dire)	7.22	°C
Td(Gefersa)	7.20	°C
A(Legadadi)	4 000 000.00	m ²
A(Dire)	650 000.00	m ²
A(Gefersa)	1 704 000.00	m ²
RH	49	%
a	17.271	-
b	237.7	-

Evaporation result		Units
E(Legadadi)	5 035 257.85	m ³ /year
E(Dire)	818 229.40	m ³ /year
E(Gefersa)	1 704 000.00	m ³ /year

Element	Monthly Max. Temp. in °C	
Region	SHOA	
Station	A.Ababa(obs)	
Year	Average max	Average min
2005	23.6	10.6
2006	23.7	10.4
2007	23.8	10.2
2008	23.4	10.4
2009	23.8	11.1
2010	22.6	11.4

APPENDIX B. The monthly rainfall data that was used.

Region Shoa
station A.A (OBS)

Monthly Total Rainfall in mm

Year	Jan	Feb	Mar	Apr	May	Jun	Jul	Aug	Sep	Oct	Nov	Dec
1990	0.8	155.9	59.2	106.4	20.0	88.8	218.7	268.6	184.0	16.2	6.0	0.0
1991	0.0	74.5	106.6	34.7	55.3	191.1	248.9	262.6	126.4	3.4	0.0	50.0
1992	20.2	33.7	20.2	41.0	52.0	109.1	248.5	294.7	209.4	69.7	0.0	2.9
1993	10.8	67.2	16.1	157.9	97.2	208.3	274.0	426.5	243.3	62.1	0.0	4.5
1994	0.0	0.0	82.4	82.3	63.3	123.4	309.1	223.0	142.0	0.5	14.7	0.0
1995	0.0	69.0	41.5	174.4	68.2	102.9	190.2	314.9	136.1	0.0	0.0	48.4
1996	28.1	5.2	106.8	128.2	122.0	258.5	266.4	338.7	294.2	0.2	0.2	0.0
1997	39.2	0.0	24.5	51.3	38.5	104.0	272.6	194.3	113.8	62.4	50.3	1.5
1998	55.2	20.5	49.0	48.5	154.2	124.4	285.4	260.0	213.6	126.9	0.0	0.0
1999	2.9	0.3	28.8	16.3	23.8	119.6	268.6	305.3	88.4	75.4	0.0	0.0
2000	0.0	0.0	17.6	49.9	110.0	144.5	244.8	306.2	250.6	46.4	21.1	0.0
2001	0.0	12.2	210.8	25.0	168.0	216.2	428.0	246.4	131.7	13.7	0.0	0.0
2002	14.7	21.0	90.2	56.3	63.1	172.5	256.9	215.9	108.8	0.2	0.0	16.5
2003	10.5	53.3	62.6	99.3	20.2	151.8	291.8	233.3	193.3	0.8	1.5	54.9
2004	24.8	20.3	49.5	139.9	30.1	141.9	248.5	268.6	164.0	76.9	0.0	0.0
2005	45.9	51.6	83.2	160.9	150.0	179.8	246.0	315.2	182.5	29.0	4.4	0.0
2006	0.7	11.2	144.9	78.9	74.6	150.1	356.3	243.6	239.1	54.0	0.3	8.0
2007	51.3	19.1	59.8	79.8	120.1	148.6	261.8	381.2	147.6	24.8	0.0	0.0
2008	0.0	13.0	0.0	49.4	94.3	88.9	277.2	360.9	256.7	88.2	79.4	22.9
2009	21.3	2.7	28.4	80.6	58.9	82.6	349.9	388.3	112.9	45.8	4.4	85.0
2010	2.6	79.8	55.5	97.8	73.8	231.1	313.9	205.8	237.8	1.8	25.7	15.0

APPENDIX C. 2020 and 2030 sub flows for all scenarios, all flows are in m³/year.

Year: 2010 Inflow 0% change				
	Legedadi	Dire	Gefersa	Total
Catchment runoff (+)	69 750 000	41 699 333	26 962 347	138 411 680
Direct rainfall (+)	5 343 600	868 335	2 276 374	8 488 309
E from dams	5 035 258	818 229	2 153 513	8 007 000
Raw water intake	49 058 920	14 779 580	11 607 000	75 445 500
Seepages	5 538 462	900 000	2 359 385	8 797 846
Spill	15 460 961	26 069 859	13 118 823	54 649 643

Year: 2020 Inflow 0% change				
	Legedadi	Dire	Gefersa	Total
Catchment runoff (+)	69 750 000	41 699 333	26 962 347	138 411 680
Direct rainfall (+)	5 343 600	868 335	2 276 374	8 488 309
E from dams (-)	5 059 295	822 135	2 163 743	8 045 173
Raw water intake (-)	49 058 920	14 779 580	11 607 000	75 445 500
Seepages (-)	5 538 462	900 000	2 359 385	8 797 846
Spill	15 436 924	26 065 953	13 108 593	54 611 470

Year: 2030 Inflow 0% change				
	Legedadi	Dire	Gefersa	Total
Catchment runoff (+)	69 750 000	41 699 333	26 962 347	138 411 680
Direct rainfall (+)	5 343 600	868 335	2 276 374	8 488 309
E from dams (-)	5 082 910	825 973	2 173 803	8 082 686
Raw water intake (-)	49 058 920	14 779 580	11 607 000	75 445 500
Seepages (-)	5 538 462	900 000	2 359 385	8 797 846
Spill	15 413 308	26 062 115	13 098 533	54 573 957

Year: 2020 Inflow 5% change				
	Legedadi	Dire	Gefersa	Total
Catchment runoff (+)	73 237 500	43 784 300	28 310 464	145 332 264
Direct rainfall (+)	5 610 780	911 752	2 390 192	8 912 724
E from dams (-)	5 059 295	822 135	2 163 743	8 045 173
Raw water intake (-)	49 058 920	14 779 580	11 607 000	75 445 500
Seepages (-)	5 538 462	900 000	2 359 385	8 797 846
Spill	19 191 604	28 194 336	14 570 529	61 956 469

Year: 2030 Inflow 5% change				
	Legedadi	Dire	Gefersa	Total
Catchment runoff (+)	73 237 500	43 784 300	28 310 464	145 332 264
Direct rainfall (+)	5 610 780	911 752	2 390 192	8 912 724
E from dams (-)	5 082 910	825 973	2 173 803	8 082 686
Raw water intake (-)	49 058 920	14 779 580	11 607 000	75 445 500
Seepages (-)	5 538 462	900 000	2 359 385	8 797 846
Spill	19 167 988	28 190 499	14 560 469	61 918 956

Year: 2020 Inflow 10% change				
	Legedadi	Dire	Gefersa	Total
Catchment runoff (+)	76 725 000	45 869 267	29 658 581	152 252 848
Direct rainfall (+)	5 877 960	955 169	2 504 011	9 337 139
E from dams (-)	5 059 295	822 135	2 163 743	8 045 173
Raw water intake (-)	49 058 920	14 779 580	11 607 000	75 445 500
Seepages (-)	5 538 462	900 000	2 359 385	8 797 846
Spill	22 946 284	30 322 720	16 032 465	69 301 468

Year: 2030		Inflow 10% change		
	Legedadi	Dire	Gefersa	Total
Catchment runoff (+)	76 725 000	45 869 267	29 658 581	152 252 848
Direct rainfall (+)	5 877 960	955 169	2 504 011	9 337 139
E from dams (-)	5 082 910	825 973	2 173 803	8 082 686
Raw water intake (-)	49 058 920	14 779 580	11 607 000	75 445 500
Seepages (-)	5 538 462	900 000	2 359 385	8 797 846
Spill	22 922 668	30 318 882	16 022 405	69 263 955